

# Washer-Extractors BCT

Installation/Maintenance/Operation

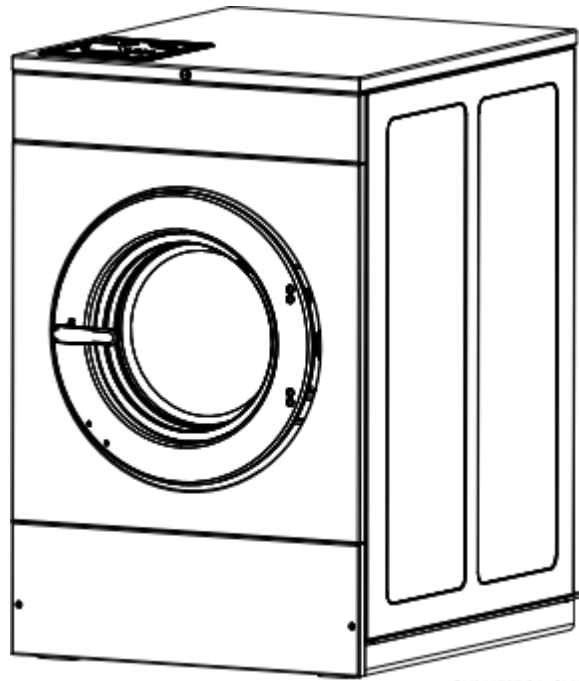

CHM1787C1\_SVG

## Original Instructions

**Keep These Instructions for Future Reference.**

**CAUTION: Read the instructions before using the machine.**

(If this machine changes ownership, this manual must accompany machine.)

# Table of Contents

<b>Safety Information.....</b>	
Explanation of Safety Messages.....	
Important Safety Instructions .....	
Safety Decals.....	
Operator Safety.....	
<b>Introduction.....</b>	
Delivery Inspection.....	
Serial Plate Location.....	
Replacement Parts.....	
Customer Service.....	
<b>Specifications and Dimensions.....</b>	
Machine Dimensions.....	
Mounting Bolt Hole Locations – 20 and 30 Models.....	
Mounting Bolt Hole Locations - 40 and 60 Models.....	
<b>Installation.....</b>	
Foundation Options.....	
Machine Installation on Existing Floor.....	
Elevated Pad Installation on Existing Floor.....	
Elevated Base Frame Installation on Existing Floor.....	
New Foundation.....	
Isolated Pad Installation.....	
Foundation and Pad Installation.....	
Floor Layout and Pad Dimensions.....	
Foundation Requirements.....	
Machine Mounting and Grouting.....	
Drain Connection Requirements.....	
Drain Hose Models - Connect Drain Hose to Drain Receptacle.....	
Water Connection Requirements.....	
Plumbing Diagrams.....	
Electrical Installation Requirements.....	
Input Power Conditioning.....	

Input Voltage Requirements.....  
Circuit Breakers and Quick Disconnects.....  
Connection Specifications.....  
    Single-Phase Connections.....  
    Three-Phase Connections.....  
    Grounding .....  
    Phase Adder.....  
    Thermal Overload Protector.....  
    CE Approval.....  
Chemical Injection Supply System.....  
External Supplies.....

**Start Up.....**  
    Basket Rotation.....

**Maintenance .....**  
    Daily.....  
        Beginning of Day.....  
        End of Day.....  
    Monthly.....  
    Quarterly.....  
    Yearly.....  
    Care of Stainless Steel.....

**Start Up.....**  
    Basket Rotation.....

**Equipment handling.....**  
    Equipment treatment method.....  
    Power off the machine.....  
    Equipment handling methods.....

**Control panel operation instructions.....**

# Safety Information

## Explanation of Safety Messages

Precautionary statements (“DANGER,” “WARNING,” and “CAUTION”), followed by specific instructions, are found in this manual and on machine decals. These precautions are intended for the personal safety of the operator, user, servicer, and those maintaining the machine.

	<b>DANGER</b>
Indicates an imminently hazardous situation that, if not avoided, will cause severe personal injury or death.	

	<b>WARNING</b>
Indicates a hazardous situation that, if not avoided, could cause severe personal injury or death.	

	<b>CAUTION</b>
Indicates a hazardous situation that, if not avoided, may cause minor or moderate personal injury or property damage.	

Additional precautionary statements (“IMPORTANT” and “NOTE”) are followed by specific instructions.

**IMPORTANT:** The word “IMPORTANT” is used to inform the reader of specific procedures where minor machine damage will occur if the procedure is not followed.

**NOTE:** The word “NOTE” is used to communicate installation, operation, maintenance or servicing information that is important but not hazard related.

## Important Safety Instructions

	<b>WARNING</b>
To reduce the risk of fire, electric shock, serious injury or death to persons when using your washer, follow these basic precautions:	
W023	

- Read all instructions before using the washer.
- Install the washer according the INSTALLATION instructions. Refer to the EARTH/GROUND instructions in the IN-

STALLATION manual for the proper earth/ground connection of the washer. All connections for water, drain, electrical power and earth/ground must comply with local codes and be made by licensed personnel when required. It is recommended that the machine be installed by qualified technicians.

- Do not install or store the washer where it will be exposed to water and/or weather.
- To prevent fire and explosion, keep the area around machine free from flammable and combustible products. Do not add the following substances or textiles containing traces of the following substances to the wash water: gasoline, kerosene, waxes, cooking oils, vegetable oils, machine oils, dry-cleaning solvents, flammable chemicals, thinners, or other flammable or explosive substances. These substances give off vapors that could ignite, explode or cause the fabric to catch fire by itself.
- Under certain conditions, hydrogen gas may be produced in a hot water system that has not been used for two weeks or more. HYDROGEN GAS IS EXPLOSIVE. If the hot water system has not been used for such a period, before using a washing machine or combination washer-dryer, turn on all hot water faucets and let the water flow from each for several minutes. This will release any accumulated hydrogen gas. The gas is flammable, do not smoke or use an open flame during this time.
- To reduce the risk of an electric shock or fire, DO NOT use an extension cord or an adapter to connect the washer to the electrical power source.
- Do not allow children to play on or in the washer. Close supervision of children is necessary when the washer is used near children. This appliance is not intended for use by young children or infirm persons without supervision. Young children should be supervised to ensure that they do not play with the appliance. This is a safety rule for all appliances.
- DO NOT reach and/or climb into the tub or onto the washer, ESPECIALLY if the wash drum is moving. This is an imminently hazardous situation that, if not avoided, will cause severe personal injury or death.
- Never operate the washer with any guards, panels and/or parts removed or broken. DO NOT bypass any safety devices or tamper with the controls.
- Use washer only for its intended purpose, washing textiles. Never wash machine parts or automotive parts in the machine. This could result in serious damage to the basket or tub.
- Use only low-sudsing, no-foaming types of commercial detergent. Be aware that hazardous chemicals may be present. Wear hand and eye protection when adding detergents and chemicals. Always read and follow manufacturer’s instructions on packages of laundry and cleaning aids. Heed all warnings or precautions. To reduce the risk of poisoning or chemical burns, keep them out of the reach of children at all times [preferably in a locked cabinet].

- Do not use fabric softeners or products to eliminate static unless recommended by the manufacturer of the fabric softener or product.
- Always follow the fabric care instructions supplied by the textile manufacturer.
- Loading door **MUST BE CLOSED** any time the washer is to fill, tumble or spin. **DO NOT** bypass the loading door switch by permitting the washer to operate with the loading door open. Do not attempt to open the door until the washer has drained and all moving parts have stopped.
- Be aware that hot water is used to flush the supply dispenser. Avoid opening the dispenser lid while the machine is running.
- Do not attach anything to the supply dispenser's nozzles, if applicable. The air gap must be maintained.
- Do not operate the machine without the water reuse plug or water reuse system in place, if applicable.
- Be sure water connections have a shut-off valve and that fill hose connections are tight. **CLOSE** the shut-off valves at the end of each wash day.
- Keep washer in good condition. Bumping or dropping the washer can damage safety features. If this occurs, have washer checked by a qualified service person.
- **DANGER:** Before inspecting or servicing machine, power supply must be turned **OFF**. The servicer needs to wait for at least 5 minutes after turning the power **OFF** and needs to check for residual voltage with a voltage meter. The inverter capacitor or EMC filter remains charged with high voltage for some time after powering **OFF**. This is an imminently hazardous situation that, if not avoided, will cause severe personal injury or death.
- Do not repair or replace any part of the washer, or attempt any servicing unless specifically recommended in the user-maintenance instructions or in published user-repair instructions that the user understands and has the skills to carry out. **ALWAYS** disconnect the washer from electrical, power and water supplies before attempting any service.
- Disconnect the power by turning off the circuit breaker or by unplugging the machine. Replace worn power cords.
- Before the washer is removed from service or discarded, remove the door to the washing compartment.
- Failure to install, maintain, and/or operate this washer according to the manufacturer's instructions may result in conditions which can produce bodily injury and/or property damage.

**NOTE: The WARNINGS and IMPORTANT SAFETY INSTRUCTIONS appearing in this manual are not meant to cover all possible conditions and situations that may occur. Common sense, caution and care must be exercised when installing, maintaining, or operating the washer.**

Any problems or conditions not understood should be reported to the dealer, distributor, service agent or the manufacturer.



## WARNING

**Machine installations must comply with minimum specifications and requirements stated in the applicable Installation Manual, any applicable municipal building codes, water supply requirements, electrical wiring regulations and any other relevant statutory regulations. Due to varied requirements and applicable local codes, this machine must be installed, adjusted, and serviced by qualified maintenance personnel familiar with applicable local codes and the construction and operation of this type of machinery. They must also be familiar with the potential hazards involved. Failure to observe this warning may result in personal injury, property damage, and/or equipment damage, and will void the warranty.**

W820

**IMPORTANT: Ensure that the machine is installed on a level floor of sufficient strength. Ensure that the recommended clearances for inspection and maintenance are provided. Never allow the inspection and maintenance space to be blocked.**



## WARNING

**Never touch internal or external steam pipes, connections, or components. These surfaces can be extremely hot and will cause severe burns. The steam must be turned off and the pipe, connections, and components allowed to cool before the pipe can be touched.**

SW014

**NOTE: All appliances are produced according the EMC-directive (Electro-Magnetic-Compatibility). They can be used in restricted surroundings only (comply minimally with class A requirements). For safety reasons there must be kept the necessary precaution distances with sensitive electrical or electronic device(s). These machines are not intended for domestic use by private consumers in the home environment.**

## Safety Decals

Safety decals appear at crucial locations on the machine. Failure to maintain legible safety decals could result in injury to the operator or service technician.

Use manufacturer-authorized spare parts to avoid safety hazards

## Operator Safety

	<b>WARNING</b>
<b>NEVER insert hands or objects into basket until it has completely stopped. Doing so could result in serious injury.</b>	

	<b>WARNING</b>
<b>Operating the machine with severe out-of-balance loads could result in personal injury and serious equipment damage.</b>	

Machines referred to by model in this manual are intended to be used by the general public in applications such as:

- staff areas in shops, offices, kitchens and other working environments
- by clients in hotels, motels and other residential type environments
- areas for communal use in blocks of flats or in launderettes
- any other similar applications

Installation of these machines must fully conform to the instructions contained in this manual.

The following maintenance checks must be performed daily:

1. Verify that all warning labels are present and legible, replace as necessary.
2. Check door interlock before starting operation of the machine:
  - a. Attempt to start the machine with the door open. The machine should not start.
  - b. Close the door without locking it and start the machine. The machine should not start.
  - c. Attempt to open the door while a cycle is in progress. The door should not open.

If the door lock and interlock are not functioning properly, disconnect power and call a service technician.

3. Do not attempt to operate the machine if any of the following conditions are present:
  - a. The door does not remain securely locked during the entire cycle.
  - b. Excessively high water level is evident.
  - c. Machine is not connected to a properly grounded circuit.

Do not bypass any safety devices in the machine.

## Customer Service

For technical assistance, contact your local distributor

## Delivery Inspection

Upon delivery, visually inspect crate, protective cover, and unit for any visible shipping damage. If signs of possible damage are evident, have the carrier note the condition on the shipping papers before the shipping receipt is signed, or advise the carrier of the condition as soon as it is discovered.

## Serial Plate Location

The serial plate is located on the rear panel and inside the door of the machine.

Always provide the machine's serial number and model number when ordering parts or when seeking technical assistance. Refer to *Figure 1*.

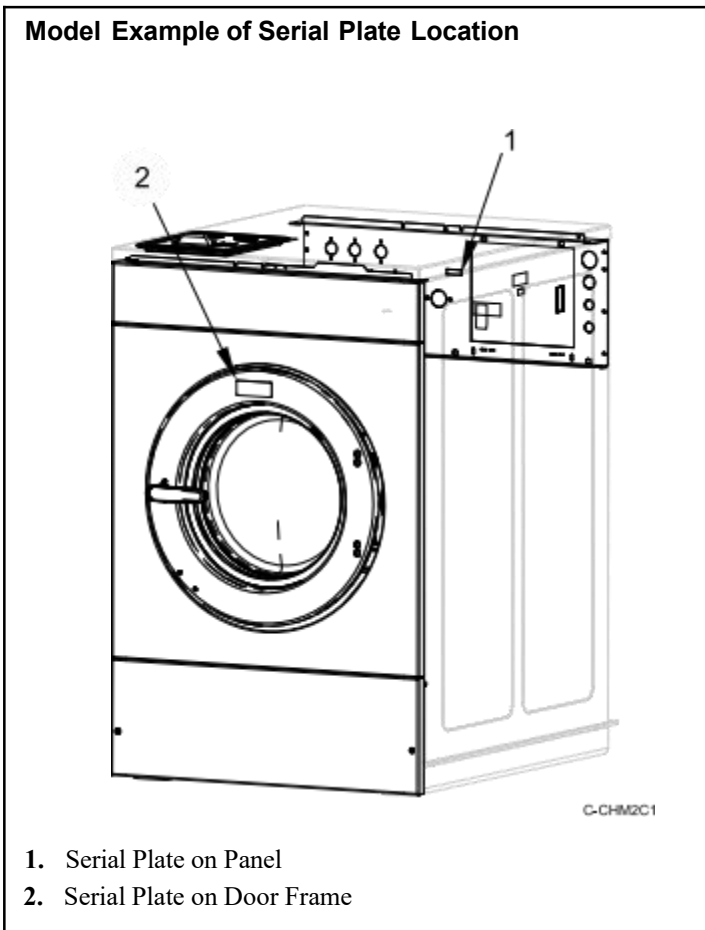

Figure 1

## Replacement Parts

If literature or replacement parts are required, contact the source from which the machine was purchased

# Specifications

		BCT030	BCT040	BCT060
CController		Touch screen	Touch screen	Touch screen
Washing capacity-lb(kg)		30(14)	40(18)	60(27)
Machine width-in(mm)		29(737)	30.6(778)	34.1(867)
Machine depth-in(mm)		34(864)	38.9(988)	41.6(1057)
Machine height-in(mm)		44.8(1138)	47.3(1202)	49.9(1268)
Drum diameter-in(mm)		24(610)	26.3(668)	30(762)
Drum depth-in(mm)		16(406)	20.3(516)	22(559)
Drum volume-cu ft(liters)		4.2(119)	6.3(178)	9.0(255)
Door open size-in(mm)		14.3(363)	16.3(414)	16.3(414)
Door bottom to the floor distance-in(mm)		14(356)	14.6(371)	4.9(378)
Cold/hot water inlet size-in(mm)		2x0.75(19)	2x0.75(19)	2x0.75(19)
Drain size-in(mm)		1x3(76)	1x3(76)	x3(76)
Drain valve to the floor distance in(mm)		4.3(109)	4.5(114)	4.9(124)
Motor power-HP(kw)		2(1.5)	2(1.5)	3(2.2)
Drum speed-RPM(G-Force)	washing	48(0.8)	46(0.8)	43(0.8)
	mid	542(100)	518(100)	485(100)
	high	766(200)	733(200)	686(200)
Net weight-1b(kg)		44(200)	54(245)	58(308)
Gross weight-lb(kg)		480(218)	580(263)	720(327)
Wooden package G.W.-lb(kg)		580(263)	680(308)	840(381)
Shipping package Approx-in(mm)	W	31.5(800)	32.5(826)	37.5(953)
	D	38.3(937)	43.5(1105)	46.9(1191)
	H	51.3(1303)	53.6(1361)	56.3(1430)

# Machine Dimensions

Front View

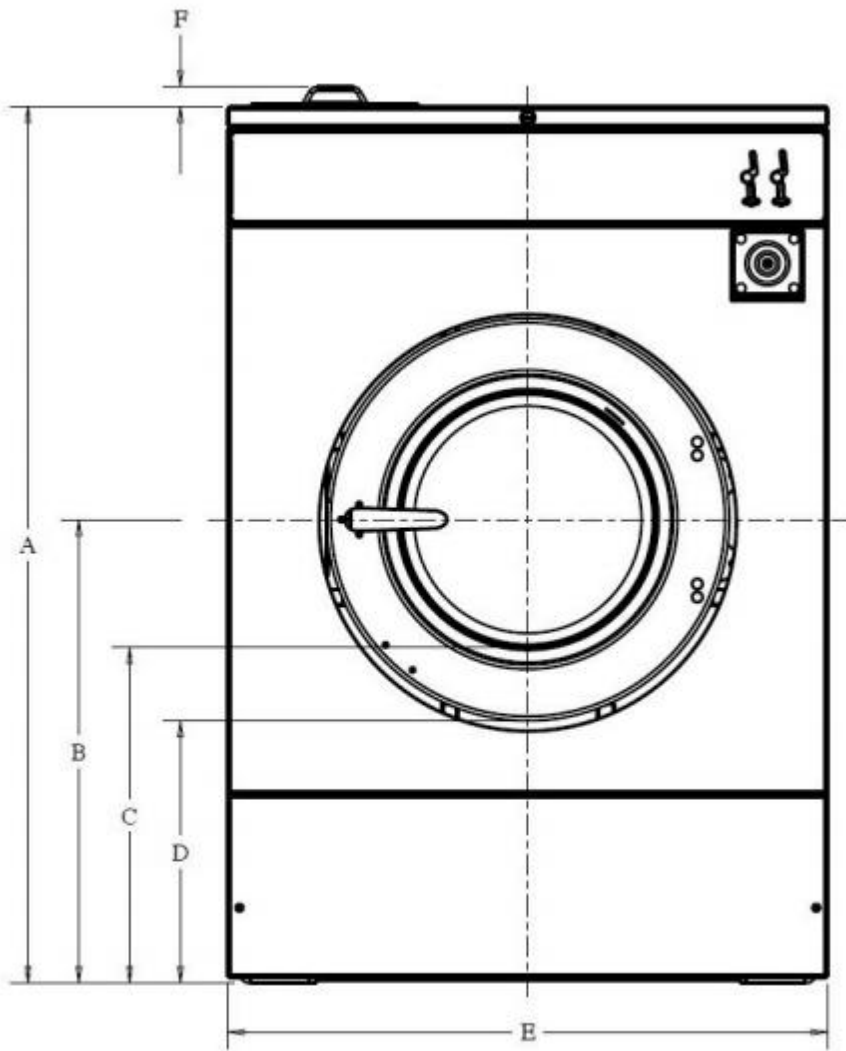

CHM2563N\_SVG

Figure 2

<b>Specification</b>	<b>30</b>	<b>40</b>	<b>60</b>
<b>A</b>	45.0 [1143]	47.2 [1199]	49.9 [1267]
<b>B</b>	24.0 [610]	26.0 [660]	26.4 [671]
<b>C</b>	17.0 [432]	17.7 [450]	18.1 [460]
<b>D</b>	14.0 [356]	14.6 [371]	14.9 [378]
<b>E</b>	29.0 [737]	30.6 [777]	34.1 [866]
<b>F</b>	1.1 [28]	1.1 [28]	1.1 [28]

Table 2

Side View

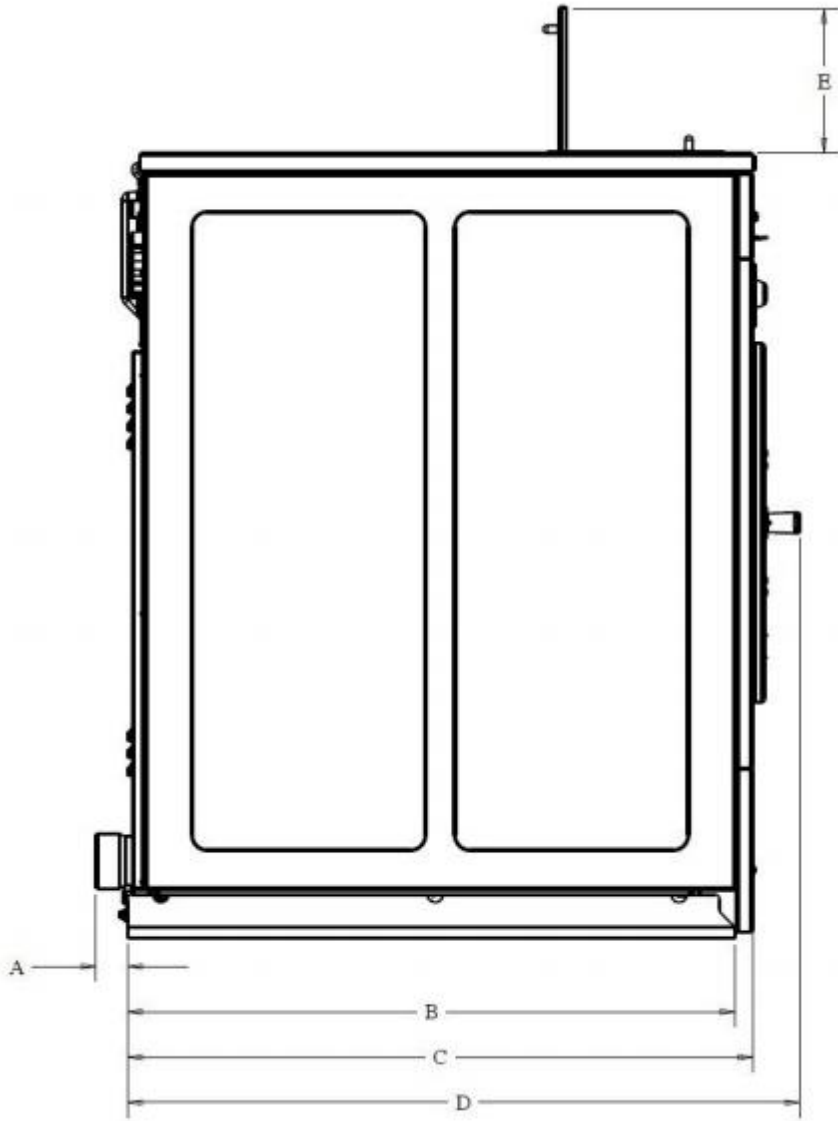

CHM2564N\_SVG

Figure 3

<b>Specification</b>	<b>30</b>	<b>40</b>	<b>60</b>
<b>A</b>	2.0 [51]	2.0 [51]	2.0 [51]
<b>B</b>	31.5 [800]	35.5 [902]	38.6 [980]
<b>C</b>	31.8 [808]	37.0 [940]	39.5 [1003]
<b>D</b>	35.3 [897]	42.3 [1074]	44.7 [1135]
<b>E</b>	9.3 [236]	9.3 [236]	9.3 [236]
Door width	19.38 [492]	21.75 [552]	21.75 [552]

Table 3

## 20-30 Models Rear View

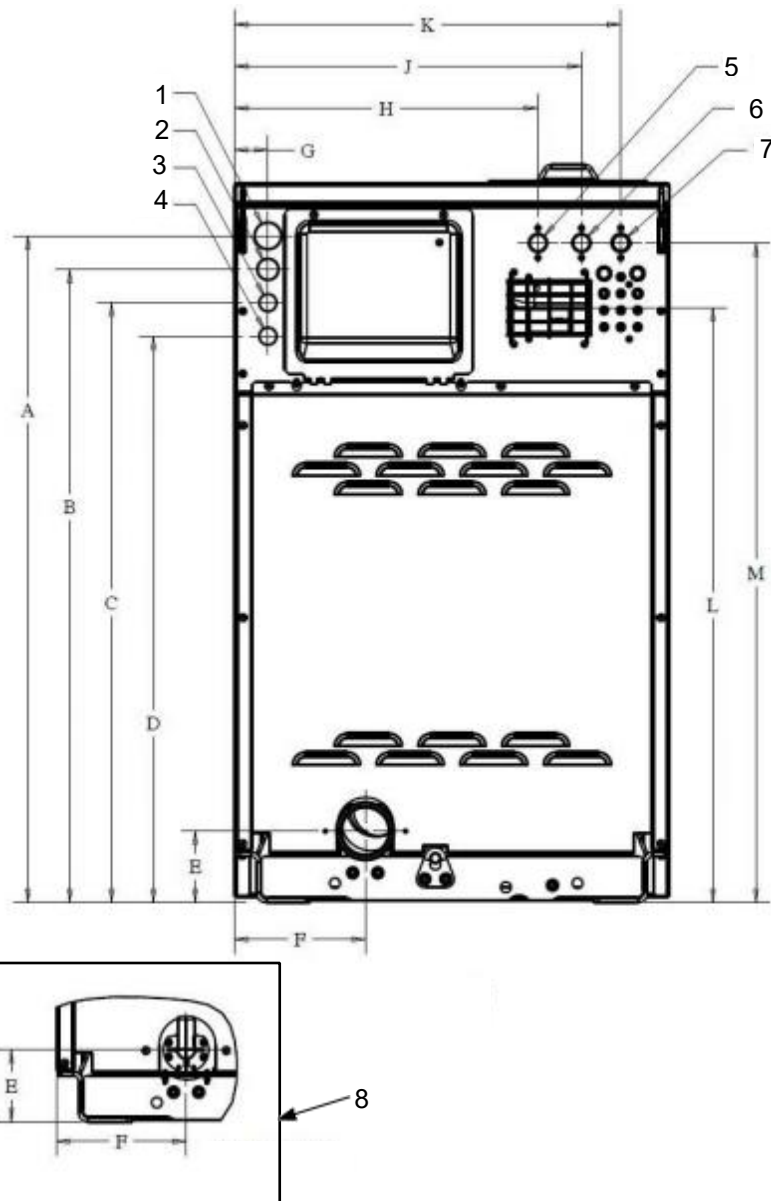

1. 1 1/2" Electrical
2. 1 1/8" Electrical
3. 7/8" Electrical
4. 7/8" Electrical
5. Compartment Cold Fill Valve
6. Compartment Hot Fill Valve
7. Cold Hard Water Valve or 3rd Water Inlet
8. Pump Drain View

CHM2565N\_SVG

Figure 4

Specifications and Dimensions

<b>Specification</b>	<b>30</b>
<b>A</b>	41.8 [1062]
<b>B</b>	39.8 [1011]
<b>C</b>	37.8 [960]
<b>D</b>	35.8 [909]
<b>E</b>	4.3 [109]
<b>F</b>	9.3 [236]
<b>G</b>	2.0 [51]
<b>H</b>	21.1 [536]
<b>J</b>	23.7 [602]
<b>K</b>	26.1 [663]
<b>L</b>	41.4 [1052]
<b>M</b>	37.5 [953]

Table 4

**40 Models Rear View**

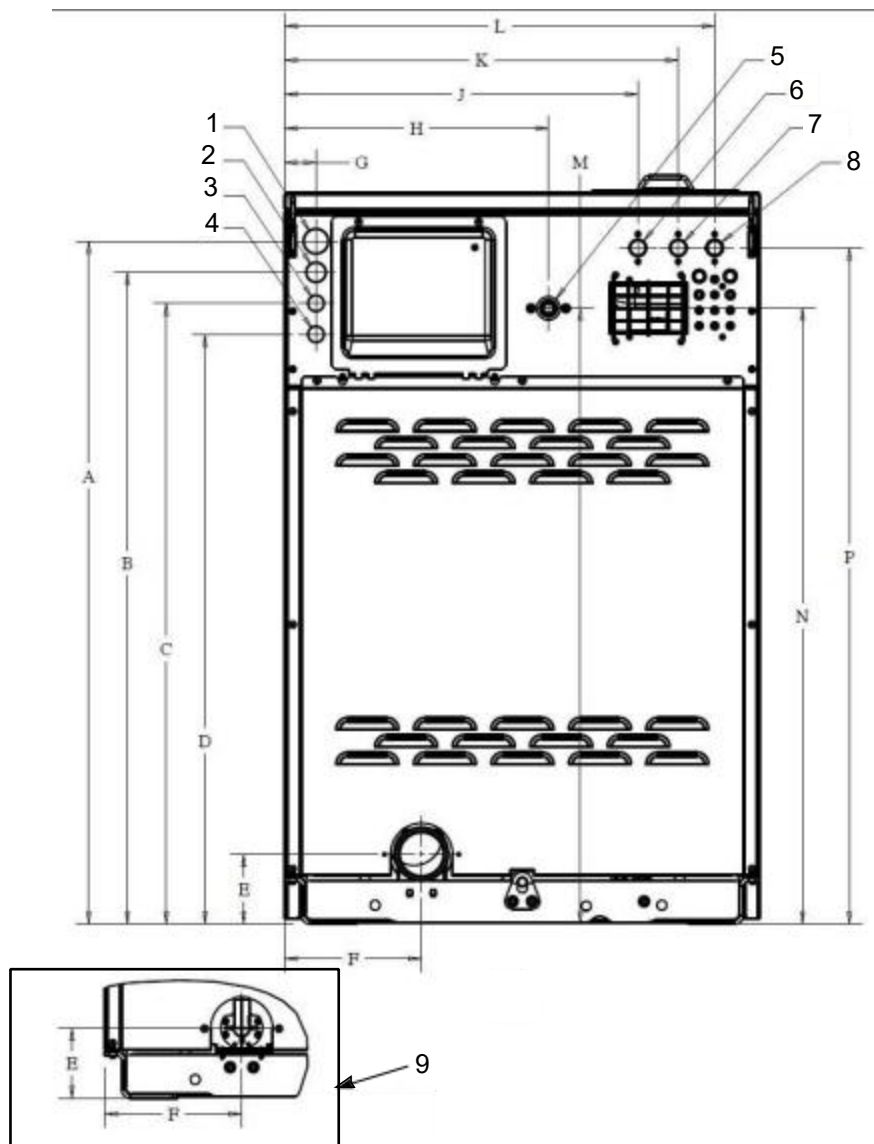

CHM2566N\_SVG

- 1. 1 1/2" Electrical
- 2. 1 1/8" Electrical
- 3. 7/8" Electrical
- 4. 7/8" Electrical
- 5. Steam Valve
- 6. Compartment Cold Fill Valve
- 7. Compartment Hot Fill Valve
- 8. Cold Hard Water Valve or 3rd Water Inlet
- 9. Pump Drain View

Figure 5

Specifications and Dimensions

<b>Machine Dimensions, in. [mm]</b>	
<b>Specification</b>	<b>40</b>
<b>A</b>	44.0 [1118]
<b>B</b>	42.0 [1067]
<b>C</b>	40.3 [1024]
<b>D</b>	38.0 [965]
<b>E</b>	4.5 [114]
<b>F</b>	8.8 [224]
<b>G</b>	17.0 [432]
<b>H</b>	2.0 [51]
<b>J</b>	22.8 [579]
<b>K</b>	25.4 [645]
<b>L</b>	27.7 [704]
<b>M</b>	39.7 [1008]
<b>N</b>	43.6 [1107]
<b>P</b>	43.5 [1105]

Table 5

**60-100 Models Rear View**

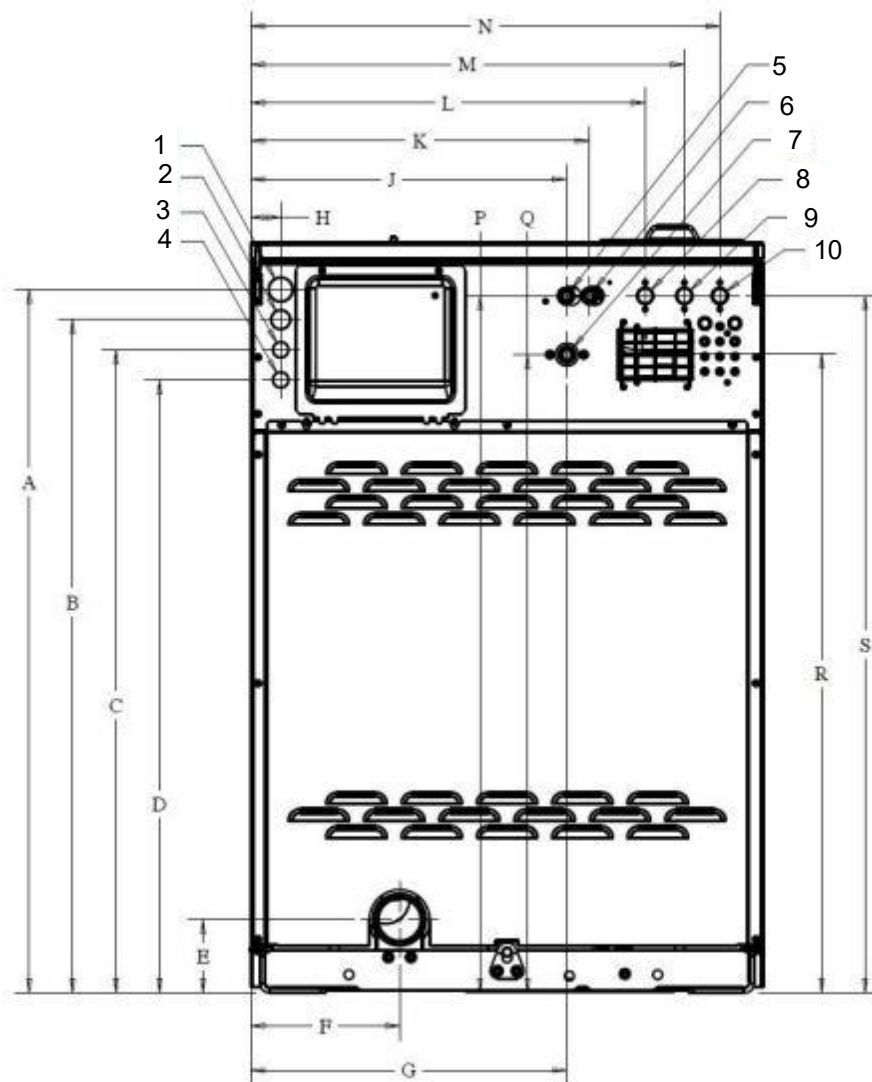

CHM2567N\_SVG

- 1. 1 1/2" Electrical
- 2. 1 1/8" Electrical
- 3. 7/8" Electrical
- 4. 7/8" Electrical
- 5. Tub Cold Fill Valve
- 6. Tub Hot Fill Valve
- 7. Steam Valve
- 8. Compartment Cold Fill Valve
- 9. Compartment Hot Fill Valve
- 10. Cold Hard Water Valve or 3rd Water Inlet

Figure 6

Specifications and Dimensions

<b>Machine Dimensions, in. [mm]</b>			
<b>Specification</b>	<b>60</b>		
<b>A</b>	46.7 [1186]		
<b>B</b>	44.7 [1135]		
<b>C</b>	42.7 [1085]		
<b>D</b>	40.7 [1034]		
<b>E</b>	4.9 [124]		
<b>F</b>	9.9 [251]		
<b>G</b>	21.0 [533]		
<b>H</b>	2.0 [51]		
<b>J</b>	21.0 [533]		
<b>K</b>	22.5 [572]		
<b>L</b>	26.2 [665]		
<b>M</b>	28.8 [732]		
<b>N</b>	31.2 [792]		
<b>P</b>	46.3 [1176]		
<b>Q</b>	42.4 [1077]		
<b>R</b>	46.3 [1176]		
<b>S</b>	42.4 [1097]		

Table 6

## Mounting Bolt Hole Locations – 20 and 30 Models

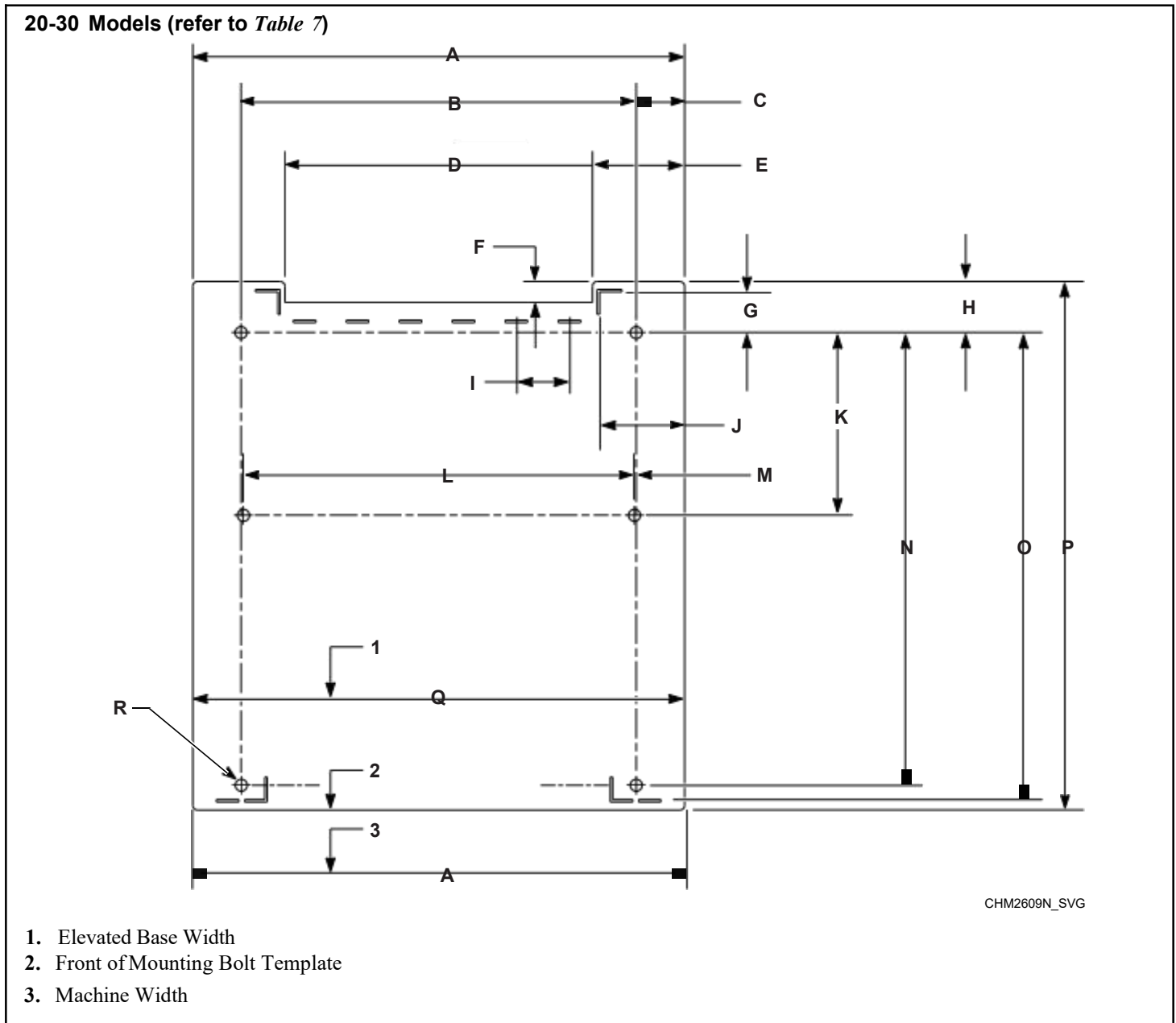

Figure 7

Specifications and Dimensions

<b>Specification</b>	<b>30</b>
<b>A</b>	29 [737]
<b>B</b>	23.886 [607]
<b>C</b>	2.558 [65]
<b>D</b>	18.87 [479]
<b>E</b>	5.065 [129]
<b>F</b>	1.033 [26]
<b>G</b>	1.81 [46]
<b>H</b>	2.37 [60]
<b>I</b>	2.813 [71]
<b>J</b>	4.51 [114]
<b>K</b>	10.5 [267]
<b>L</b>	23.5 [597]
<b>M</b>	0.188 [5]
<b>N</b>	28.938 [735]
<b>O</b>	29.69 [754]
<b>P</b>	32.38 [597]
<b>Q</b>	29 [737]
<b>R</b>	0.641 [16]

Table 7

# Mounting Bolt Hole Locations - 40 and 60 Models

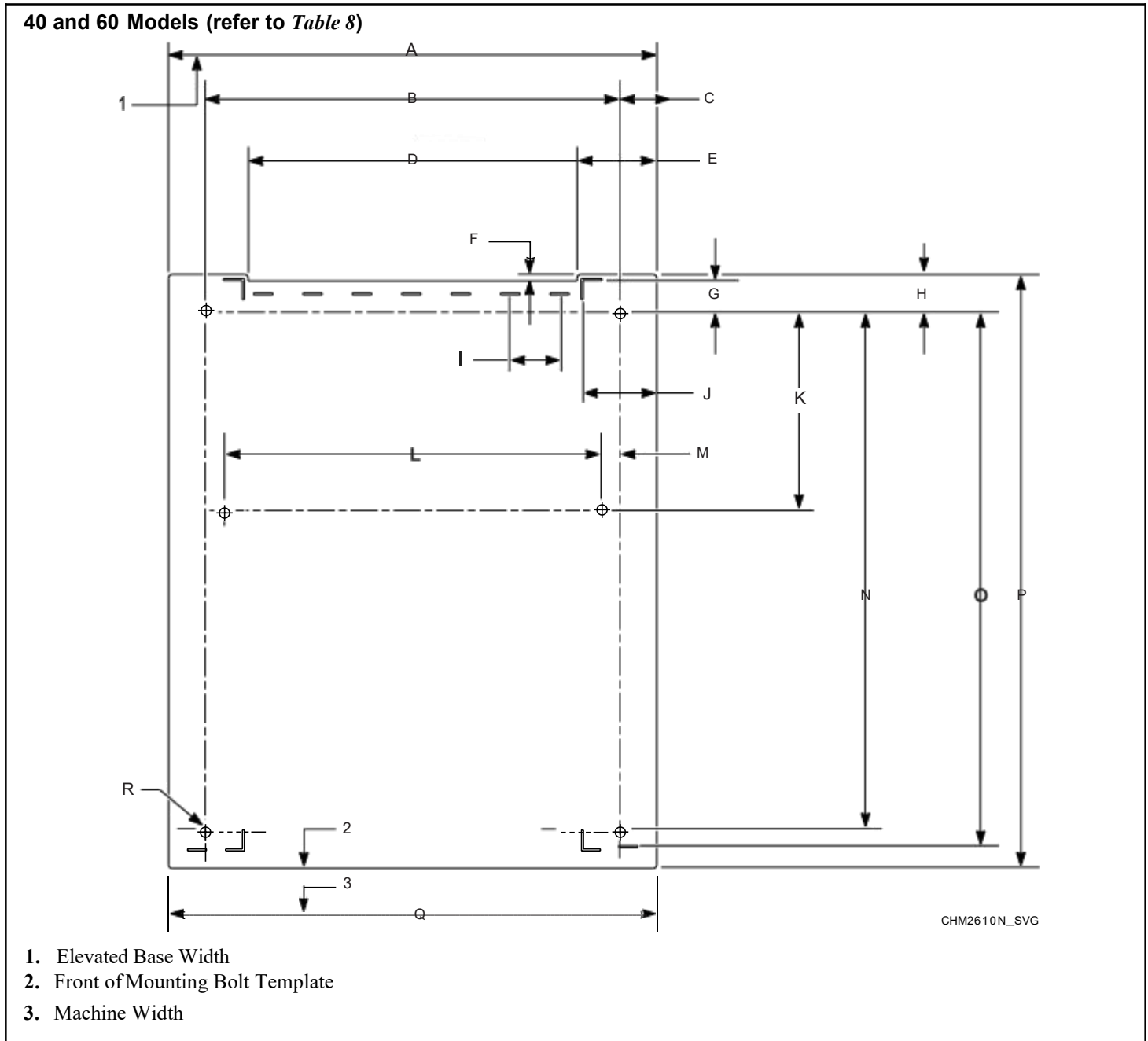

Figure 8

<b>Mounting Bolt Hole Locations - 40 and 60 Models, in. [mm]</b>		
<b>Specification</b>	<b>40</b>	<b>60</b>
<b>A</b>	30.63 [778]	34.06 [865]
<b>B</b>	26 [660]	30 [762]
<b>C</b>	2.315 [59]	2.03 [52]
<b>D</b>	20.63 [524]	23.39 [594]
<b>E</b>	5 [127]	5.34 [136]
<b>F</b>	0.422 [11]	0.614 [16]
<b>G</b>	1.98 [50]	1.75 [44]
<b>H</b>	2.37 [60]	2.37 [60]
<b>I</b>	3.1 [79]	3.28 [83]
<b>J</b>	4.63 [118]	4.96 [126]
<b>K</b>	12.5 [318]	11.927 [303]
<b>L</b>	23.626 [600]	27.5 [699]
<b>M</b>	1.187 [30]	1.25 [32]
<b>N</b>	32.5 [826]	36 [914]
<b>O</b>	33.54 [852]	36.87 [699]
<b>P</b>	37.36 [949]	40.7 [1034]
<b>Q</b>	30.6 [777]	34.1 [866]
<b>R</b>	0.641 [16]	0.641 [16]

Table 8

# Installation

## Foundation Options

A minimum 3500 psi (refer to rating per supplier) reinforced concrete set on a prepared bed is required for all new machine installations.

**NOTE: Do not mount on wooden floors, tile floors, elevated floor levels, stacked multiple base frames, or over basements or crawl spaces because of the high extract speed and the G-forces exerted. For 80 models and larger, do not mount on metal base frames.**

Thoroughness of detail must be stressed with all foundation work to ensure a stable unit installation, eliminating possibilities of excessive vibration during extract.



### WARNING

To reduce the risk of fire, serious injury, property damage and/or death, install the machine on a level (within 3/8 inch), uncovered concrete floor of sufficient strength at grade.

W787

For new foundations a mounting bolt template is available at extra cost or use machine base if available.

The machine must be anchored to a smooth level surface so that the entire base of the machine is supported and rests on the mounting surface.

**IMPORTANT: Do not permanently support the machine on only four points with spacers. Grouting is required and spacers must be removed.**

### Machine Installation on Existing Floor

The existing floorslab must be reinforced concrete without voids under slab and meet depth requirements per *Table 20*. If the floor meets these requirements and an elevated pad is NOT desired, refer to *Figure 18* and proceed to *Machine Mounting and Grouting*. If the floor does not meet these requirements and an elevated pad is NOT desired, refer to *Figure 21* and proceed to *Machine Mounting and Grouting*.

### Elevated Pad Installation on Existing Floor

The existing floorslab must meet minimum requirements shown in *Foundation Requirements* per machine. The floor must be reinforced concrete without voids under slab. If the slab meets these requirements and an elevated pad is desired, refer to *Figure 20* and proceed to *Machine Mounting and Grouting*.

### Elevated Base Frame Installation on Existing Floor

The existing floorslab must meet minimum requirements shown in *Machine Foundation and Pad Installation* per machine. The floor must be reinforced concrete without voids under slab. Refer to *Figure 18* and *Figure 19*. If the slab does not meet these requirements and an elevated base frame is desired, refer to *Figure 21*. Proceed to *Machine Mounting and Grouting*.

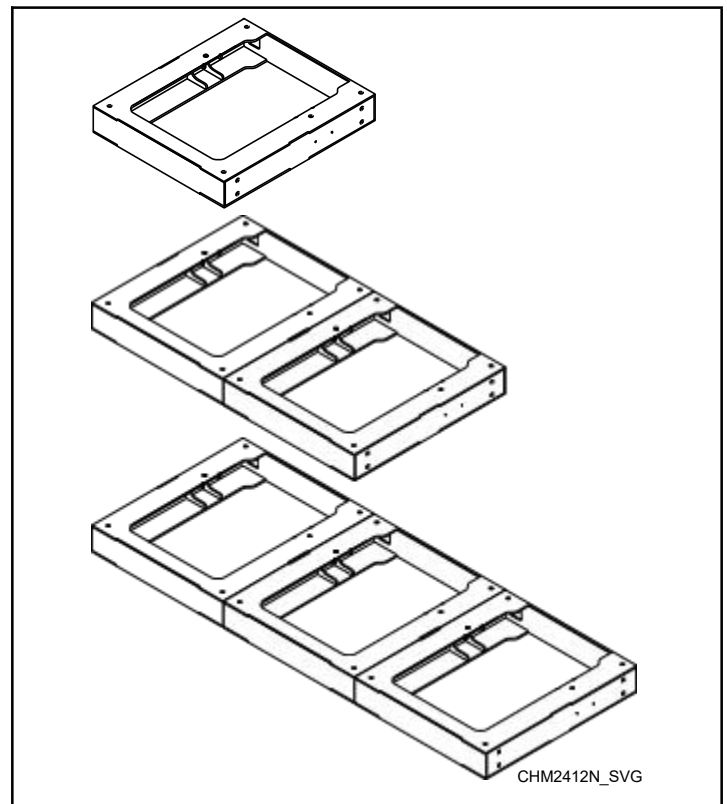

Figure 10

### New Foundation

If the existing floorslab does not meet the single machine foundation requirements per model and/or a new monolithic foundation is desired, refer to *Figure 19* and proceed to *Foundation and Pad Installation*.



### Isolated Pad Installation

This type of installation is NOT recommended. Installer MUST consult a Structural Engineer for concrete specifications and requirements for installations that will not be tied into adjacent foundations.

**IMPORTANT: The above instructions and recommendations are conservative specifications for a typical installation based on consultations with a structural engineer. Alliance Laundry Systems stands behind all installations meeting these specifications. For alternate installation specifications based on your soil type, location, building structure, unique floor geometry, machine types, and utilities, consult a structural engineer in your local area.**

### Foundation and Pad Installation

A concrete pad may be constructed to elevate a machine. Care must be exercised in the design of the pad due to the force exerted by the machine during extract. This concrete pad, recommended not to exceed 8 inches [203 mm] above existing floor, must be placed, reinforced with rebar and tied to the existing floor. Refer to *Floor Layout and Pad Dimensions* and *Foundation Requirements* sections for multiple machine installations.

Elevated Pad, in. [mm]					
Description		20-30	40-60 (Feed)	40-60 (V-speed)	
<b>A</b>	Height of elevated pad above floor (maximum)	8 [203]	8 [203]	8 [203]	
<b>B</b>	Distance between reinforcing bars (maximum)	12 [305]	12 [305]	12 [305]	
<b>C</b>	Length of reinforcing bar extending into existing floor (minimum)	2.5 [64]	2.5 [64]	2.5 [64]	
<b>D</b>	Total depth of foundation (concrete plus 6 in. [152 mm] fill) (minimum)	8 [203]	8 [203]	12 [305]	

Table 11 continues...

Elevated Pad, in. [mm]					
Description		20-30	40-60 (Feed)	40-60 (V-speed)	
<b>E</b>	Required thickness of existing floor (minimum)	4 [102]	4 [102]	6 [152]	

Table 11

**IMPORTANT: Do NOT install a pad on top of the existing floor. The foundation and pad must be constructed and tied together as one piece.**

If the existing floor is not reinforced concrete at least 12 inches [305 mm] thick, an elevated pad is desired or multiple machines are to be installed, the following steps must be performed (refer to *Foundation Requirements*):

1. Cut a hole through the existing floor that is larger on all sides than the machine base, refer to *Floor Layout and Pad Dimensions*.
2. Excavate to a depth as indicated in *Table 11* from the top of the existing floor.
3. If installing a foundation with elevated pad, prepare a form for the above-ground portion of the foundation. Verify that the top of the foundation is level. The height of the foundation pad must not exceed 8 inches [203 mm] above the existing floor.
4. Backfill with clean fill dirt.
5. Compact backfill, making sure to allow for correct concrete thickness.
6. Drill holes (refer to manufacturer's requirements for drill hole size) for the perimeter reinforcing bar at a depth of 2-1/2 inches [64 mm] into the existing floor. The reinforcing should be 12 inches [305 mm] on center each way around entire perimeter.
7. Clean out debris from each reinforcing bar hole.
8. Fill half the hole depth with acrylic adhesive.  
**NOTE: Procure acrylic adhesive rated for commercial-grade vibratory machine installations**
9. Using #4 [60 ksi] reinforcing bar, tie new pad to existing floor making sure to tie reinforcing bars at the intersections and using proper reinforcing bar supports to hold bars at the proper depth in the pad.
10. Allow adhesive around reinforcing bar to cure properly, refer to adhesive manufacturer for recommended cure times.
11. Completely fill with 3500 psi concrete up to the existing foundation level plus any added level (maximum of 8 inch

[203 mm] ) for the desired elevated pad. The concrete must be poured so that the entire foundation and pad cures as one piece.

12. Allow concrete to cure, refer to manufacturer's recommended cure times.
13. Using a mounting bolt template or machine base, mark where the holes should be drilled to mount the machine.

**NOTE: As an alternate method, cast in the Grade 5 (minimum SAE rating), 5/8 inch [16 mm] for 20-60 models and 3/4 inch [19 mm] for 80 and 100 anchor bolts as the concrete is poured, refer to *Figure 23* and *Table 24* .**

14. Proceed to *Machine Mounting and Grouting*.

# Floor Layout and Pad Dimensions

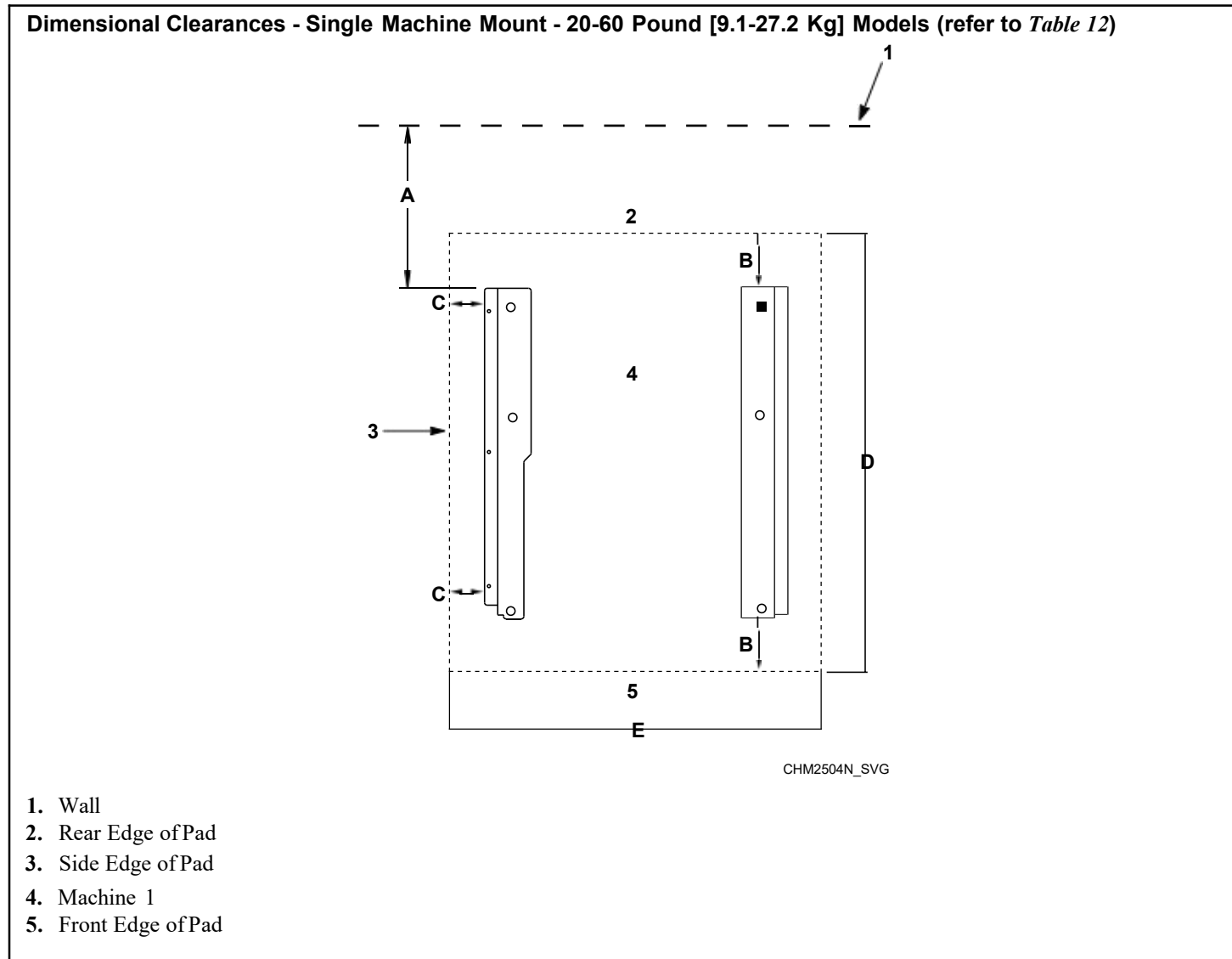

Figure 11

Dimensional Clearances - Single Machine Mount - 20-60 Pound [9.1-27.2 Kg] Models, in. [mm]					
Description		20	30	40	60
A	Distance to wall (minimum)	24 [610]	24 [610]	24 [610]	24 [610]

Table 12 continues...

## Installation

Dimensional Clearances - Single Machine Mount - 20-60 Pound [9.1-27.2 Kg] Models, in. [mm]					
Description		20	30	40	60
B	Distance of machine base to edge of pad (minimum)	3.44 [87]	4 [102]	3.99 [101]	5.99 [152]



<b>Description</b>		<b>30</b>	<b>40</b>	<b>60</b>
<b>A</b>	Distance to wall (minimum)	24 [610]	24 [610]	24 [610]
<b>B</b>	Mounted without bases (minimum)	5.12 [130]	4.63 [118]	4.06 [103]
	Mounted with bases (minimum)	5.5 [139]	4.88 [124]	4.44 [112]
<b>C</b>	Length of pad (minimum)	39.5 [1003]	43.5 [1105]	50.6 [1285]
<b>D</b>	Width of pad (minimum)	63.52 [1613]	67.38 [1711]	78.98 [2006]
<b>E</b>	Side clearance between machines	.5 [13]	.5 [13]	.5 [13]

Table 13

**Dimensional Clearances - Back-to-Back Mount - 20-60 Pound [9.1-27.2 Kg] Models (refer to Table 14)**

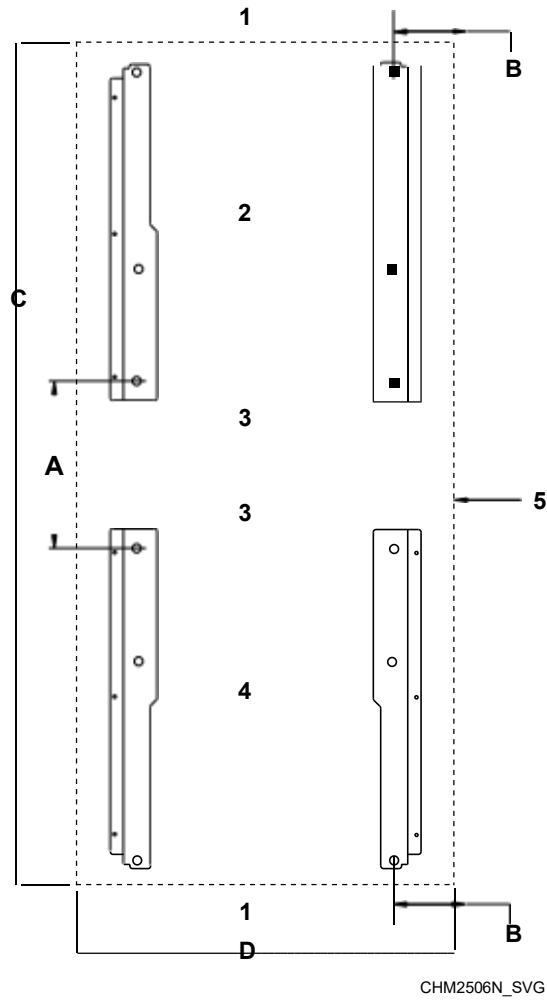

- 1. Front-facing Edge of Pad
- 2. Machine 2
- 3. Rear of Machine
- 4. Machine 1
- 5. Side Edge of Pad or Wall

Figure 13

Dimensional Clearances - Back-to-Back Mount - 20-60 Pound [9.1-27.2 Kg] Models, in. [mm]					
Description		20	30	40	60
<b>A</b>	Adjacent rear bolt spacing (minimum)	28.3 [719]	27.6 [702]	28.0 [710]	27.5 [699]
<b>B</b>	Distance from front bolt to edge of pad (minimum)	5.26 [134]	5.26 [134]	6.19 [157]	8.9 [226]
<b>C</b>	Length of pad (minimum)	88.63 [2251]	98.37 [2499]	115.23 [2927]	119.48 [3035]

Table 14 continues...

Dimensional Clearances - Back-to-Back Mount - 20-60 Pound [9.1-27.2 Kg] Models, in. [mm]					
Description		20	30	40	60
<b>D</b>	Width of pad (minimum)	31.4 [798]	34.4 [874]	36.5 [927]	44.8 [1138]

Table 14

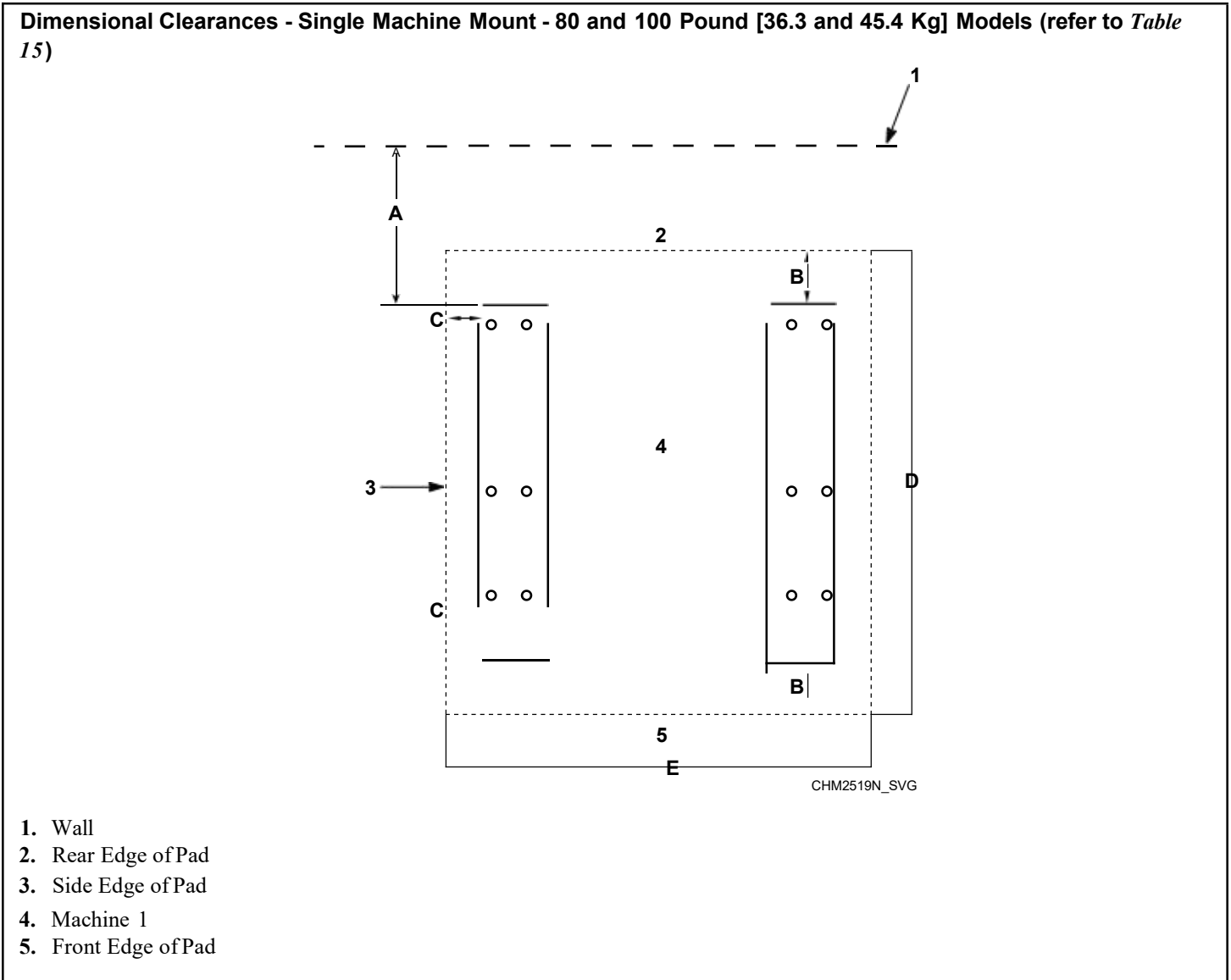

Figure 14

<b>Pad Thickness Requirements, in. [mm]</b>						
<b>Specification</b>		<b>20</b>	<b>30</b>	<b>40</b>	<b>60</b>	
Minimum Foundation Thickness	F-speed	4 [102]	4 [102]	4 [102]	4 [102]	
	V-speed	4 [102]	4 [102]	6 [152]	6 [152]	
Minimum Excavation Depth	F-speed	8 [203]	8 [203]	8 [203]	8 [203]	
	V-speed	8 [203]	8 [203]	12 [305]	12 [305]	

Table 19

# Foundation Requirements

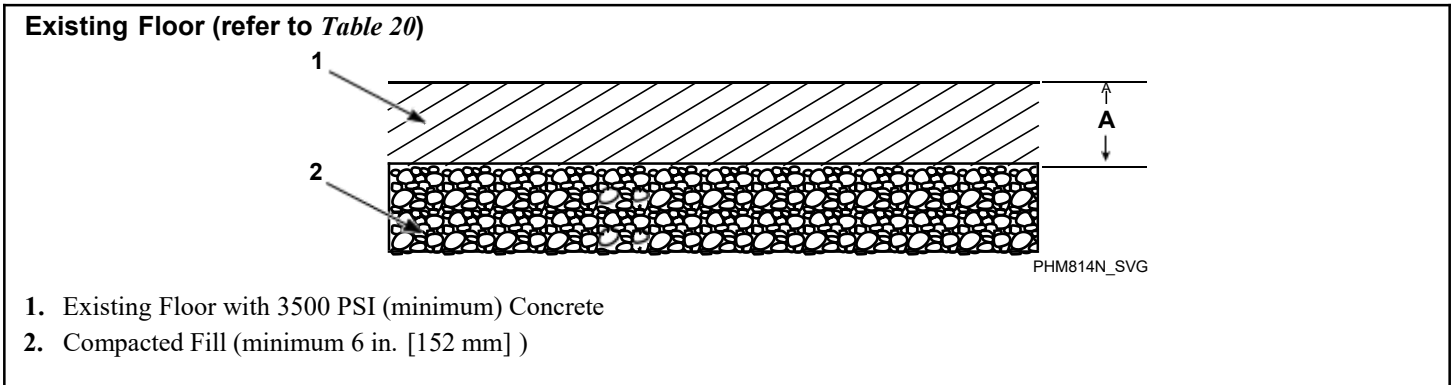

Figure 18

		Existing Floor, in. [mm]		
Description		20-30	40-60 (F-speed)	40-60 (V-speed) / 80-100 (F-speed)
A	Required thickness of existing floor (minimum)	4 [102]	4 [102]	6 [152]

Table 20

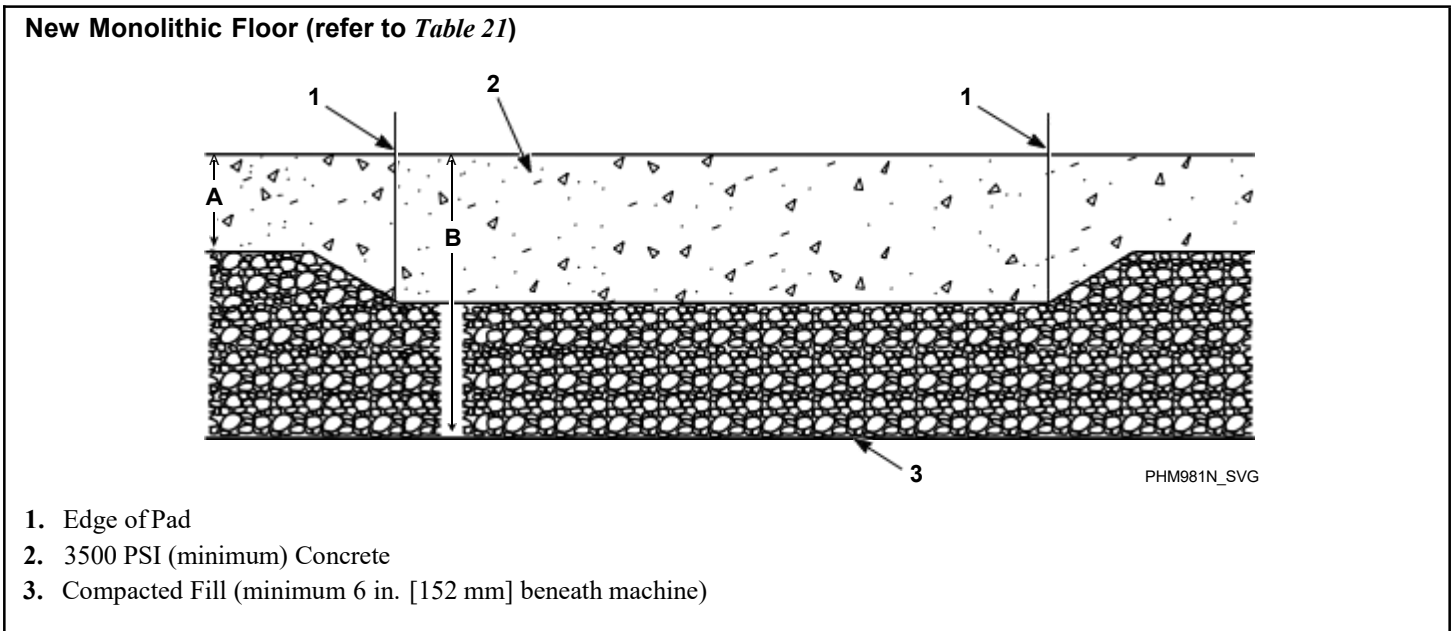

Figure 19

<b>New Monolithic Floor, in. [mm]</b>					
<b>Description</b>		<b>20-30</b>	<b>40-60 (F-speed)</b>	<b>40-60 (V-speed) / 80-100 (F-speed)</b>	
<b>A</b>	<b>Depth of Surrounding Floor</b>	4 [102]	4 [102]	6 [152]	
<b>B</b>	<b>Total depth of foundation (concrete plus 6 in. [152 mm] fill) (minimum)</b>	10 [254]	10 [254]	12 [305]	

Table 21

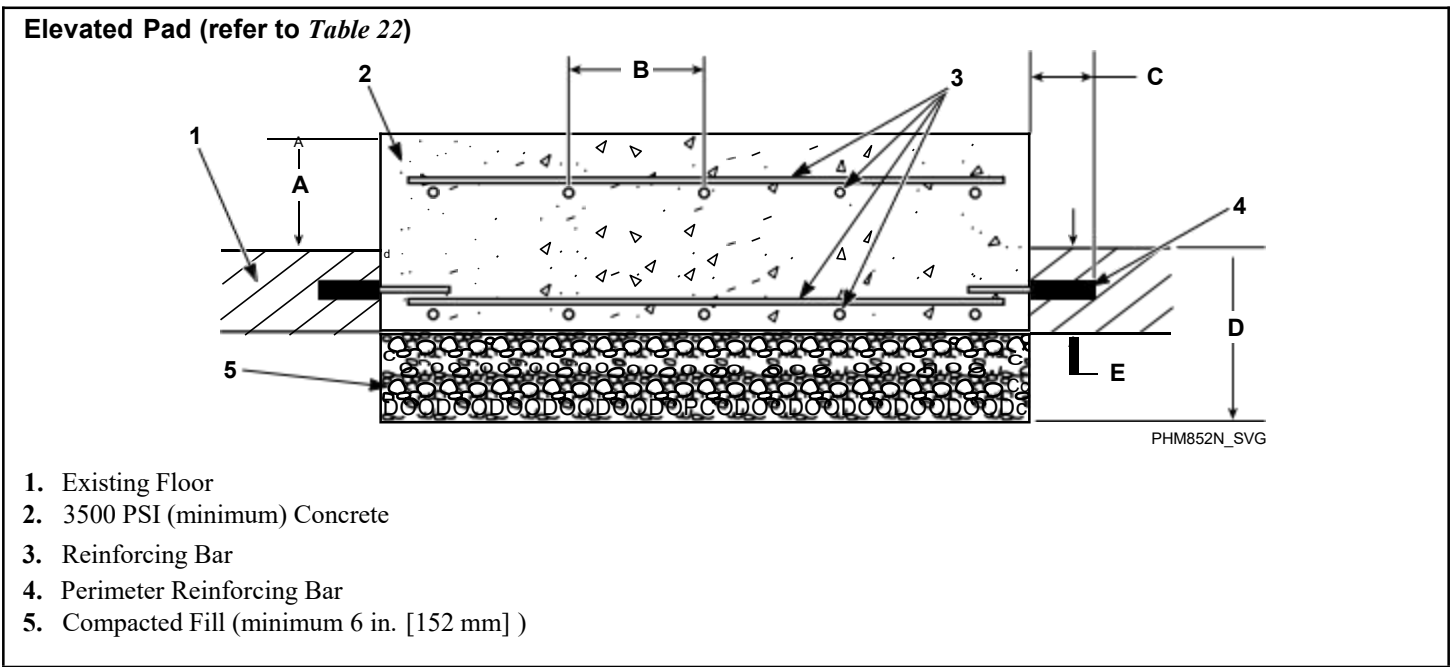

Figure 20

Elevated Pad, in. [mm]					
Description		20-30	40-60 (F-speed)	40-60 (V-speed) / 80-100 (F-speed)	
A	Height of elevated pad above floor (maximum)	8 [203]	8 [203]	8 [203]	
B	Distance between reinforcing bars (maximum)	12 [305]	12 [305]	12 [305]	
C	Length of reinforcing bar extending into existing floor (minimum)	2.5 [64]	2.5 [64]	2.5 [64]	
D	Total depth of foundation (concrete plus 6 in. [152 mm] fill) (minimum)	10 [254]	10 [254]	12 [305]	
E	Required thickness of existing floor (minimum)	4 [102]	4 [102]	6 [152]	

Table 22

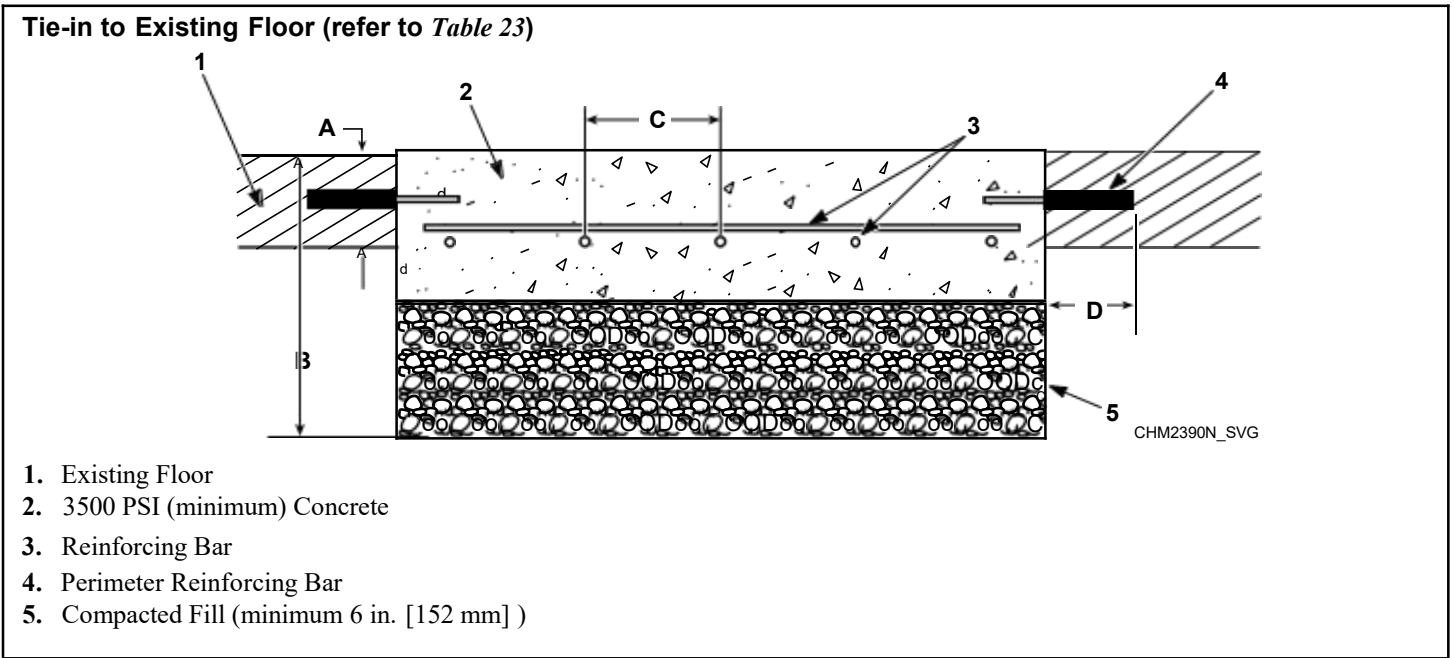

Figure 21

Tie-in to Existing Floor, in. [mm]					
Description		20-30	40-60 (F-speed)	40-60 (V-speed) / 80-100 (F-speed)	
A	Required thickness of existing floor (minimum)	4 [102]	4 [102]	6 [152]	
B	Total depth of foundation (concrete plus 6 in. [152 mm] fill) (minimum)	10 [254]	10 [254]	12 [305]	
C	Distance between reinforcing bars (minimum)	12 [305]	12 [305]	12 [305]	
D	Length of reinforcing bar extending into existing floor (minimum)	2.5 [64]	2.5 [64]	2.5 [64]	

Table 23

## Machine Mounting and Grouting

**NOTE:** After the concrete has cured completely and the cast-in-place method was used, refer to *Figure 23* and proceed to Step 7. If acrylic adhesive anchors are desired, refer to *Figure 22* and proceed with Step 1 after concrete has cured completely.

1. Refer to *Table 24* to set the drill depth gauge.
2. Drill the holes to the set depth.
3. Use compressed air or squeeze bulb to clean out debris from each hole.
4. Fill half the hole depth with an industry-accepted adhesive anchoring system.
5. Insert anchor bolt until it reaches the bottom. Refer to *Table 24*.
6. Ensure all air pockets are removed from adhesive surrounding the bolt.
7. Allow adhesive around bolt to cure completely.
8. Remove shipping materials and place the machine or elevated base frame carefully over the bolts.

**NOTE:** Never attempt to lift the machine by the door handle or by pushing on the cover panels. Always insert a pry bar or other lifting device under the bottom frame of the machine to move it.

**IMPORTANT:** DO NOT install 80 models or larger machines on an elevated metal base frame.

9. Raise and level the machine or elevated base frame 1/2 inch [1.27 cm] off the floor on four corners, using spacers such as nut fasteners.

	<b>WARNING</b>
Crush hazard. To avoid personal injury and/or property damage, do not tip the machine more than 25 degrees in any direction.	
W793	

10. Completely fill the space between the elevated base frame or machine base and the floor with a good quality **non-shrinking machinery precision grout** to ensure a stable installation. Grout completely underframe. Remove front panel and back panel to gain access to **entire perimeter of base plates**. Force grout under base until all voids are filled.

**IMPORTANT:** Minimum Grade 5, SAE rating, flat washers and minimum Grade 5, SAE rating, serrated hex flange locknuts are the recommended hardware for anchoring machine or elevated base frame to anchor bolts.

11. Position the flat washers and locknuts on the anchor bolts and finger-tighten to machine base or elevated base frame.
12. Allow machine grout to set, but not cure.

**IMPORTANT:** Refer to bolt manufacturer's recommended adhesive cure times.

13. Remove the spacers carefully, allowing the machine base or elevated base frame to settle into the wet grout.

**NOTE:** If installing a 20-60 model directly to finished floor, wait until grout is completely cured and skip to Step 18. If installing on elevated base frame, proceed to Step 14.

### 20-60 Models

14. After the grout is completely cured, position the machine over the elevated base frame.
15. Align the mounting holes on the machine with the corresponding holes on the elevated base frame.
16. Install a bolt, flat washer and locknut in each mounting hole.
17. Hand tighten each nut.
  - a. Tighten the two rear nuts two turns.
  - b. Tighten the two front nuts two turns.
  - c. Tighten the two middle nuts firmly.
18. Torque all the locknuts to 90 ± 9 ft.-lbs. – one after the other – until all are tightened evenly and the machine is fastened securely to the elevated base frame or floor.

**IMPORTANT:** Refer to recommended grout cure times from manufacturer before torquing locknuts.

**IMPORTANT:** All torque joints must remain dry (non-lubricated).

**NOTE:** Check and retighten the locknuts after five to ten days of operation and every month thereafter.

**Acrylic Adhesive Anchors (refer to Table 24)**

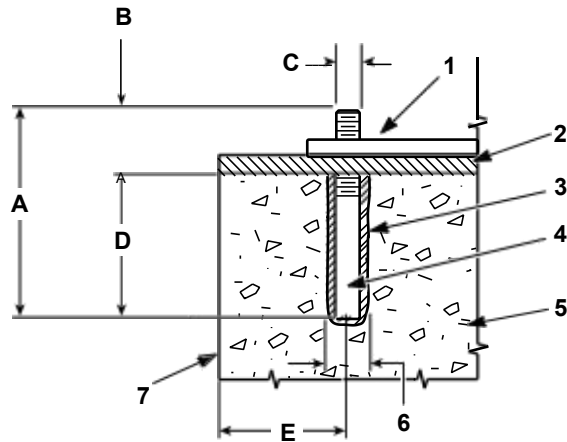

PHM811N\_SVG

**NOTE: \*Available for purchase through the distributor. If not purchasing from a distributor, procure acrylic adhesive rated for commercial-grade vibratory machine installations.**

1. Machine Frame Base
2. Grout 1/2 in. [13 mm]
3. Acrylic Adhesive\*
4. Anchor Bolt\* (minimum Grade 5 SAE rating)
5. Concrete
6. Drill Hole Size per Manufacturer Requirements
7. Edge of Pad

Figure 22

**Cast-in-place Anchors (refer to Table 24)**

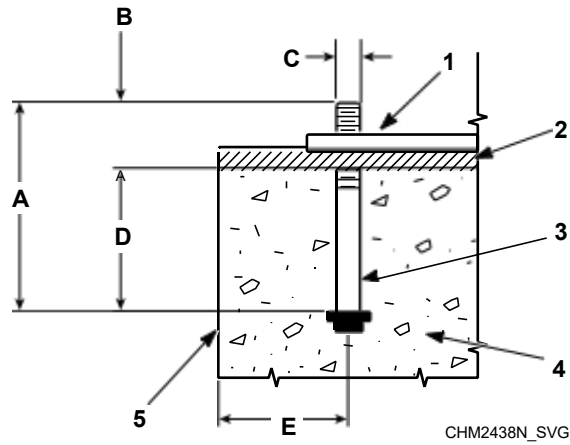

1. Machine Frame Base
2. Grout
3. Anchor Bolt (minimum Grade 5 SAE rating)
4. Concrete
5. Edge of Pad

Figure 23

Installation

Minimum Anchoring Specifications, in. [mm]							
Description		20	30	40	60		
Number of Bolts		4 or 6*	4 or 6*	4 or 6*	6		
<b>A</b>	Bolt Length	6 [152]	6 [152]	6 [152]	6 [152]		
<b>B</b>	Thread Extension	2-1/2 [64]	2-1/2 [64]	2-1/2 [64]	2-1/2 [64]		
<b>C</b>	Bolt Diameter	5/8 [16]	5/8 [16]	5/8 [16]	5/8 [16]		
<b>D</b>	Embedment Depth	3-1/2 [89]	3-1/2 [89]	3-1/2 [89]	3-1/2 [89]		
<b>E</b>	Distance from Bolt Center to Edge of Concrete Pad	5.26 [134]	5.26 [134]	6.19 [157]	8.9 [226]		

\* On 20-40 models, the four (4) corner bolts are required and the two (2) center bolts are optional when mounting a machine or elevated base frame to floor.

Table 24

Floor Load Data							
Specification		20	30	40	60		
Static floor load, lbs. [kN]		430 [1.91]	550 [2.45]	690 [3.07]	920 [4.09]		
Static pressure, lbs.-ft <sup>2</sup> [kN-m <sup>2</sup> ]		97 [4.64]	95 [4.55]	98 [4.69]	105 [5.03]		

Dynamic floor load, lbs. [kN]		420 [1.86]	630 [2.80]	840 [3.74]	1260 [5.61]		
Dynamic floor pressure, lbs.-ft <sup>2</sup> [kN-m <sup>2</sup> ]		96 [4.60]	109 [5.22]	119 [5.70]	143 [6.85]		
Dynamic load frequency, Hz	F-speed	9.7	9.0	8.6	8.1		
	V-speed	13.7	12.8	12.2	11.4		
Maximum moment about machine base, lbs.-ft. [kN-m]		805 [1.09]	1260 [1.71]	1820 [2.47]	2770 [3.76]		
Maximum vertical load, lbs. [kN]		800 [3.56]	1130 [5.03]	1460 [6.49]	2060 [9.16]		

Table 25

## Drain Connection Requirements

**IMPORTANT: Machine must be installed in accordance with all local codes and ordinances.**

All drain systems must be vented to prevent an air lock or siphoning.

Use the supplied black rubber adapter and clamps to transition from the machine drain outlet to the 3 inches [76 mm] schedule 40 PVC plumbing.

If proper drain size is not available or practical, a surge tank is required. A surge tank along with a sump pump should be used when gravity drainage is not possible.

### Drain Trough System

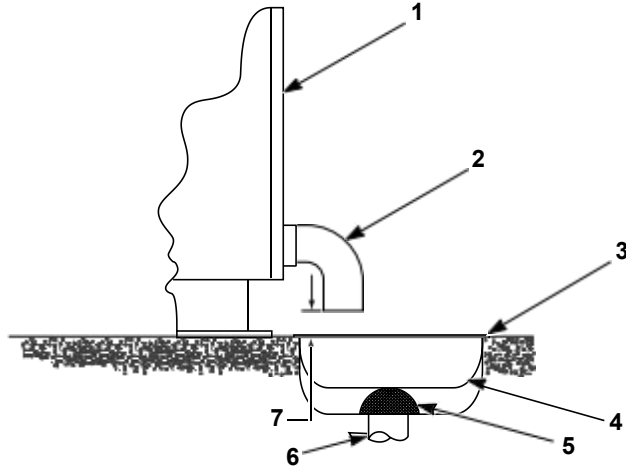

CHM2379N\_SVG

1. Rear of Machine
2. Drain Pipe
3. Steel Grate
4. Drain Trough
5. Strainer
6. Waste Line
7. 1 in. [25 mm] minimum gap

Figure 24

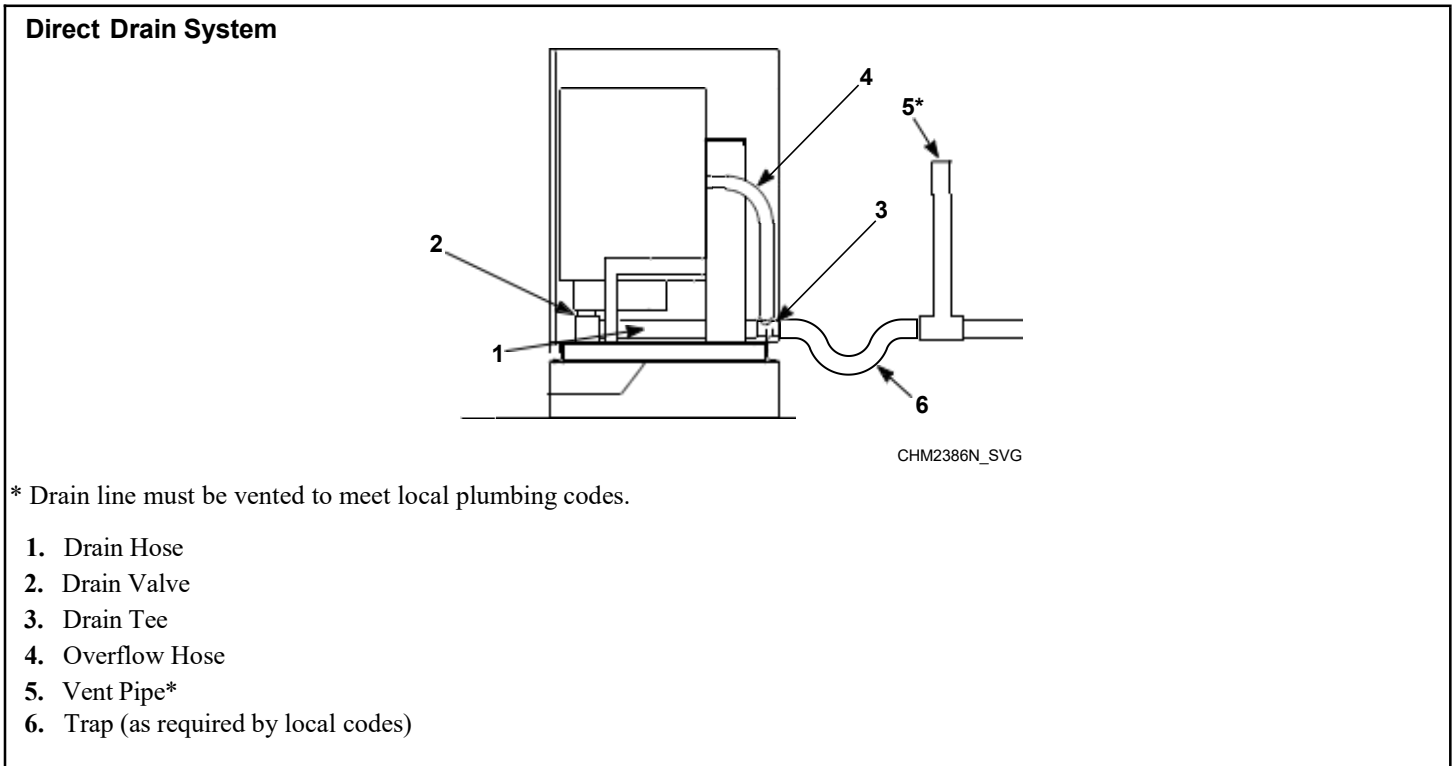

Figure 25

**IMPORTANT: Increasing the drain hose length, installing elbows, or causing bends will decrease drain flow rates and increase drain times, impairing machine performance.**

Drain Information						
Specification	20	30	40	60		
Drain connection size, in.	3 *	3 *	3 *	3 *		
Overflow drain connection size, in.	1-1/2	2-1/4	2-1/4	2-1/4		
Number of drain outlets	1	1	1	1		
Drain flow capacity, gal/min [l/min]	25 [95]	30 [114]	40 [151]	50 [189]		
Maximum discharge (level 30), gal [l]	11.2 [42]	23.9 [90]	27.4 [104]	30.8 [117]		
Recommended drain pit size, ft <sup>3</sup> [l]	2.0 [57]	2.5 [71]	3.5 [128]	5.7 [161]		
* Also works with 3 inch OD PVC pipe if connected to inside of drain tee connector.						

Table 26

## Drain Hose Models - Connect Drain Hose to Drain Receptacle

Remove the drain hose from its shipping position on the rear of the washer by removing the shipping tape.

**IMPORTANT: Drain receptacle must be capable of handling a minimum of 1-3/8 inch [35 mm] outside diameter drain hose.**

Drain Flow Rate - 100-127 Volt/60 Hertz	
Drain Height	Flow Rate gallons per minute [liters per minute]
3 ft. [0.9 m]	8.6 [32.7]
5 ft. [1.5 m]	6.8 [25.9]
6 ft. [1.8 m]	6.0 [22.7]
7 ft. [2.1 m]	5.1 [19.5]
8 ft. [2.4 m]	4.0 [15.2]
Drain Flow Rate - 220-240 Volt/50 Hertz	
Drain Height	Flow Rate gallons per minute [liters per minute]
3 ft. [0.9 m]	7.3 [27.7]
5 ft. [1.5 m]	4.7 [17.8]
6 ft. [1.8 m]	3.5 [13.4]
7 ft. [2.1 m]	1.3 [4.8]
8 ft. [2.4 m]	0 [0]
Drain Flow Rate - 208-240 Volt/60 Hertz	
Drain Height	Flow Rate gallons per minute [liters per minute]
3 ft. [0.9 m]	9.4 [35.5]
5 ft. [1.5 m]	7.6 [28.8]
6 ft. [1.8 m]	6.6 [25.1]
7 ft. [2.1 m]	5.6 [21.2]
8 ft. [2.4 m]	4.3 [16.4]

## Water Connection Requirements



### WARNING

To prevent personal injury, avoid contact with inlet water temperatures higher than 125° Fahrenheit [51° Celsius] and hot surfaces.

W748

The maximum water inlet temperature for vented models is 125°F [51°C] and the recommended maximum water inlet temperature for on-premises models is 150°F [66°C] (standard models) or 140°F [60°C] (WRAS approved models) .

Connections should be supplied by a hot and a cold water line of at least the sizes shown in *Water Supply Line Sizing*. Installation of additional machines will require proportionately larger water lines.

Connections should be supplied by a hot and a cold water line per national and local codes and in accordance with AS/NZS 3500.I.

# Plumbing Diagrams

20-60 Models - Side View (refer to *Table 29*)

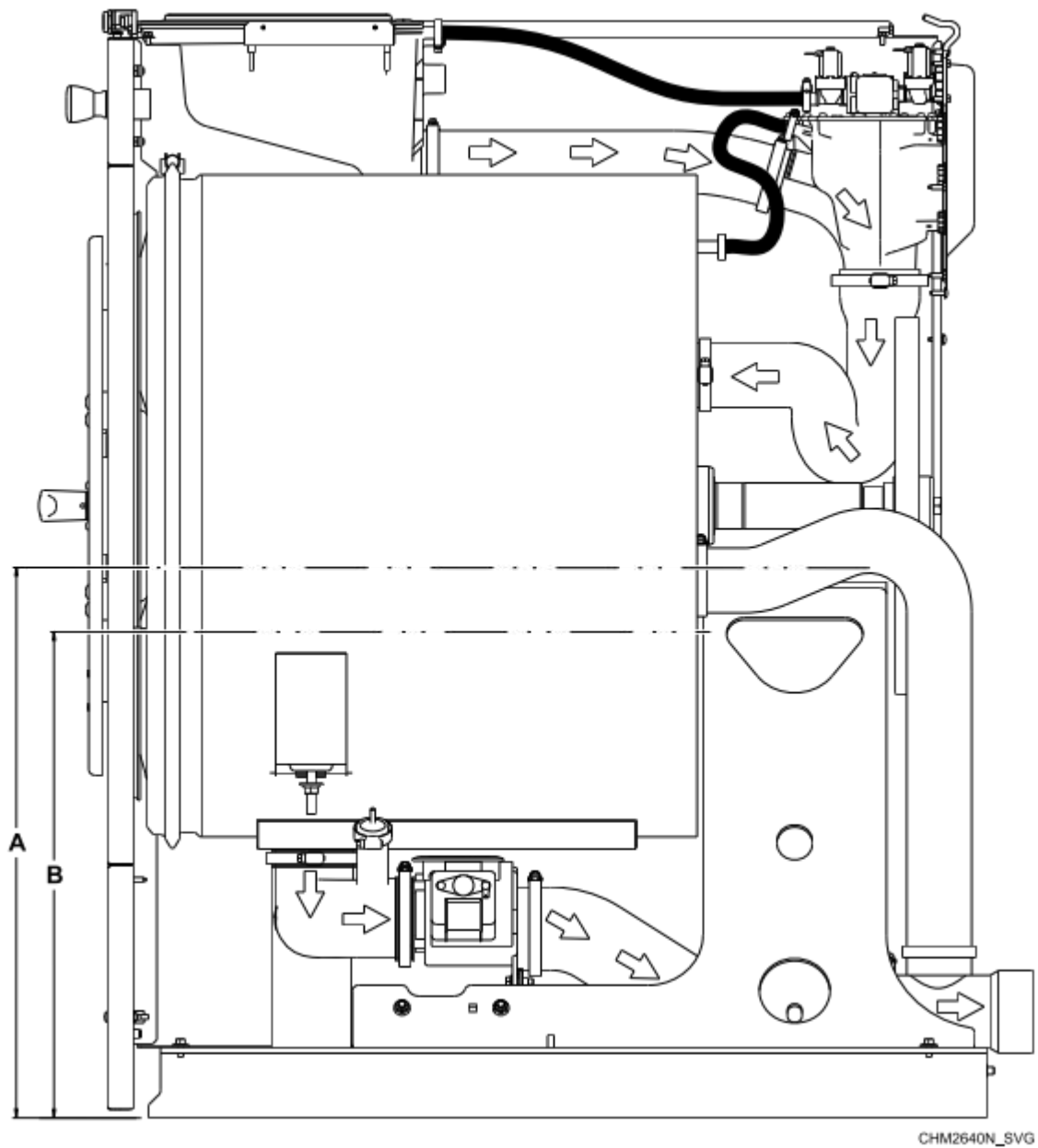
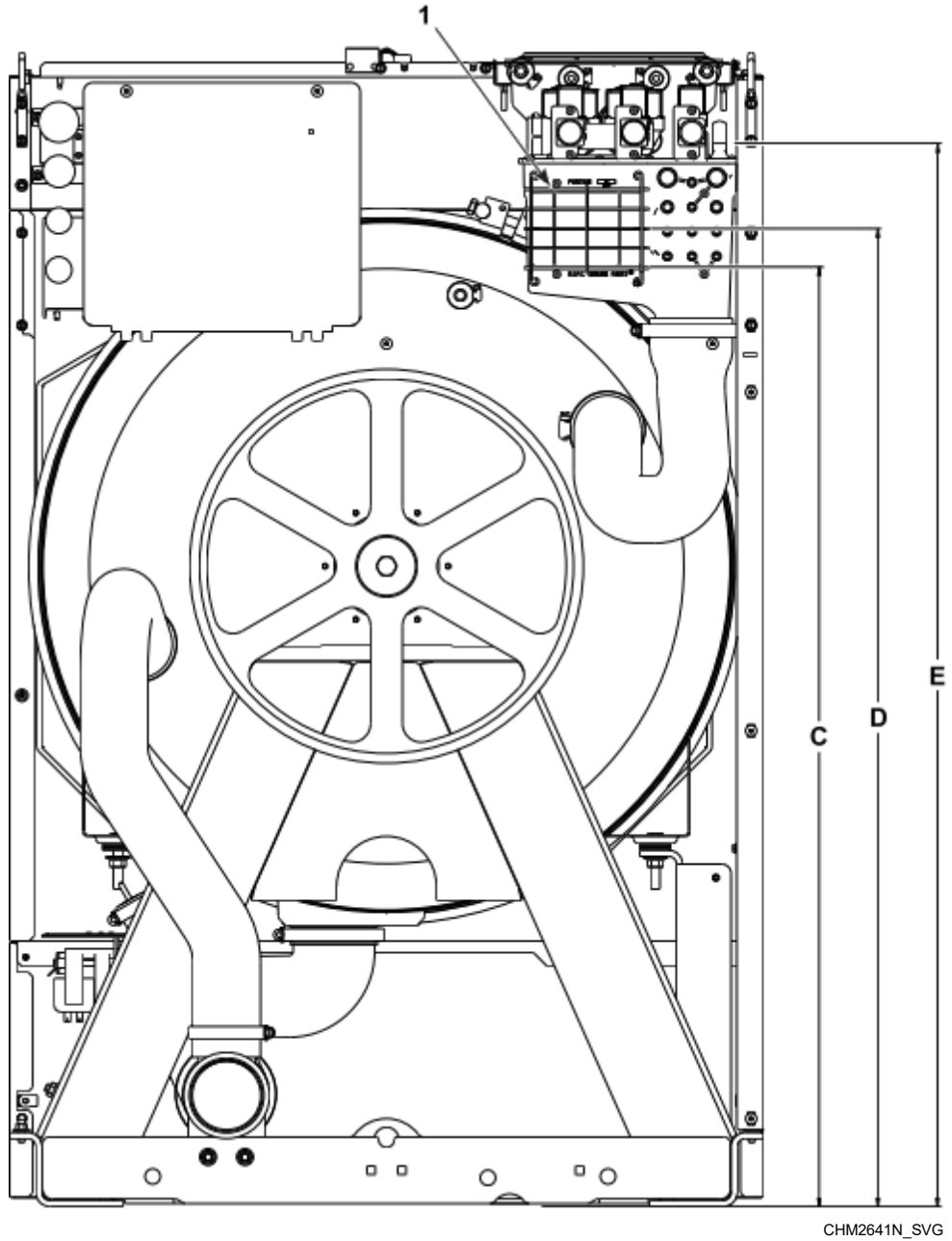

Figure 31

20-60 Models - Rear View (refer to *Table 29*)



CHM2641N\_SVG

- 1. Vacuum Breaker Overflow

Figure 32

**Plumbing Diagram - 20-60 Models, in. [mm]**

<b>Description</b>		<b>20</b>	<b>30</b>	<b>40</b>
A	Maximum overflow height	20.5 [521]	21.4 [544]	23.1 [587]
B	Maximum operating water level	18.5 [470]	17.0 [432]	19.9 [505]
C	Vaccum breaker overflow	33.9 [861]	35.8 [909]	38.0 [965]
D	Vaccum breaker overflow centerline	35.5 [902]	37.5 [953]	39.7 [1008]
E	Inlet Valves	38.9 [988]	41.4 [1052]	43.2 [1097]

Table 29

60-100 Models - Side View (refer to Table 30)

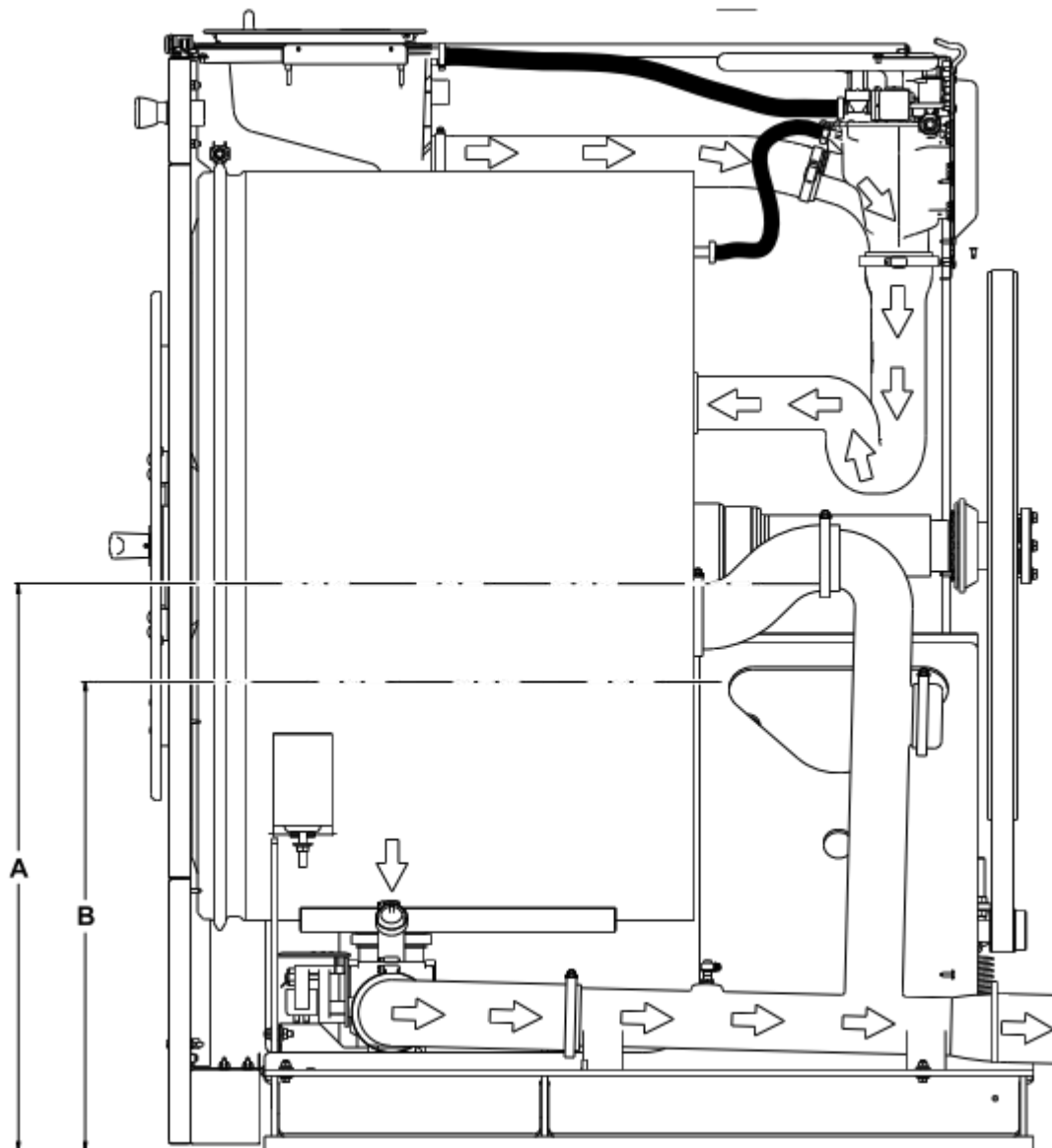

CHM2642N\_SVG

Figure 33

60 Models - Rear View (refer to *Table 30*)

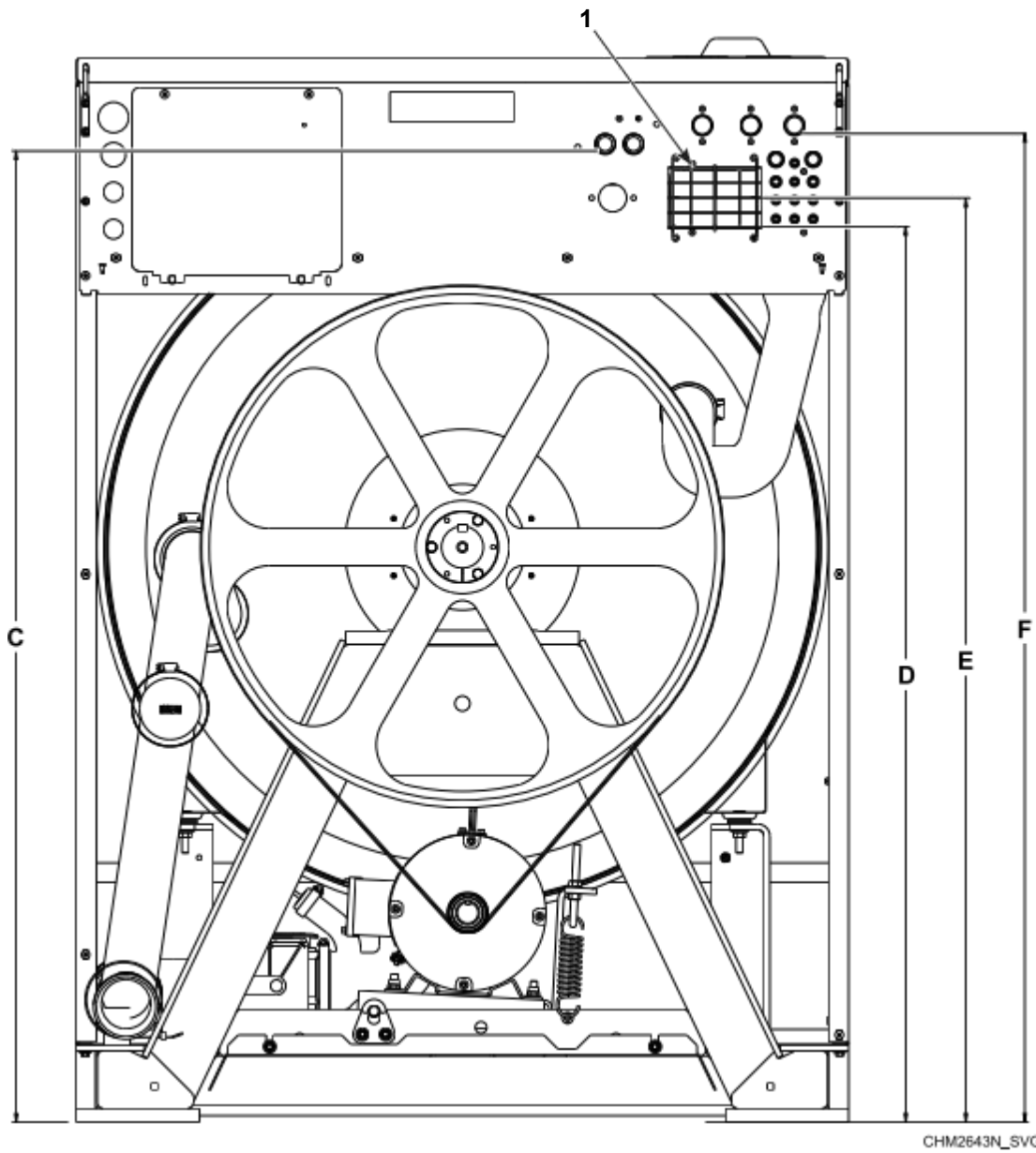

1. Vacuum Breaker Overflow

Figure 34

Plumbing Diagram - 60-100 Models, in. [mm]			
Description		60	
A	Maximum overflow height	23.1 [587]	
B	Maximum operating water level	20.6 [523]	
C	Aux Inlet valves	45.8 [1163]	
D	Vaccum breaker overflow	40.7 [1034]	
E	Vaccum breaker overflow centerline	42.4 [1077]	
F	Inlet Valves	45.9 [1166]	

Table 30

### Electrical Installation Requirements

**IMPORTANT:** Electrical ratings are subject to change. Refer to serial plate for electrical ratings information specific to your machine.

	<b>DANGER</b>
<p>Electrical shock hazard will result in death or serious injury. Disconnect electric power and wait five (5) minutes before servicing.</p>	
W810	

	<b>WARNING</b>
<p>Dangerous voltages are present inside the machine. Only qualified personnel should attempt adjustments and troubleshooting. Disconnect power from the machine before removing any cover and guards, and before attempting any service procedures.</p>	
W736	

	<b>WARNING</b>
<p>Hazardous Voltage. Can cause shock, burn or death. Verify that a ground wire from a proven earth ground is connected to the lug near the input power block on this machine.</p>	
W360	

	<b>WARNING</b>
<p>This Machine produces excessive leakage current. Do not use a grounding conductor smaller than 10mm<sup>2</sup>.</p>	
W946	

**NOTE:** For voltages above or below listed specification, a qualified electrical contractor must be consulted to install the appropriate transformer to meet the OEM electrical specifications. Refer to *Electrical Specifications (North American Approval)* and *Electrical Specifications (CE Approval)*.

Electrical connections are made at the rear of the machine. The machine must be connected to the proper electrical supply shown on the serial plate on the rear of the machine, using copper conductors only.

**IMPORTANT:** Alliance Laundry Systems warranty does not cover components that fail as a result of improper input voltage.

Machines are equipped with an AC inverter drives requiring a clean power supply, free from voltage spikes and surges. Use voltage monitor to check incoming power.

## Input Power Conditioning

The drive is suitable for direct connection to input power within the rated voltage of the drive. Listed in *Input Power Condition* are certain input power conditions which may cause component damage or reduction in product life. If any of the conditions exist,

install one of the devices listed under the Possible Corrective Action(s).

**IMPORTANT: Only one device per branch circuit is required. It should be mounted closest to the branch and sized to handle the total current of the branch circuit.**

Input Power Condition	Possible Corrective Action(s)
Low Line impedance (less than 1% line reactance)	<ul style="list-style-type: none"> <li>• Install Line Reactor</li> <li>• Isolation Transformer</li> </ul>
Greater than 120 kVA supply transformer	
Line has power factor correction capacitors	<ul style="list-style-type: none"> <li>• Install Line Reactor</li> <li>• Isolation Transformer</li> </ul>
Line has frequent power interruptions	
Line has intermittent noise spikes in excess of 3000V (lightning)	
Phase to ground voltage exceeds 125% of normal line to line voltage	<ul style="list-style-type: none"> <li>• Remove MOV jumper to ground</li> <li>• Install Isolation Transformer with grounded secondary (if necessary)</li> </ul>
Ungrounded distribution system	
240V open delta configuration (stinger leg)*	<ul style="list-style-type: none"> <li>• Install Line Reactor</li> </ul>
<p>* For drives applied on an open delta with a middle phase grounded neutral system, the phase opposite the phase that is tapped in the middle to the neutral or earth is referred to as the “stinger leg,” “high leg,” “red leg,” etc. This leg should be identified throughout the system with red or orange tape on the wire at each connection point. The stinger leg should be connected to the center Phase B on the reactor.</p>	

Table 31

## Input Voltage Requirements

For voltages above or below listed specifications, contact your power company or local electrician.

**IMPORTANT: Improper connections will result in equipment damage and will void warranty.**

**IMPORTANT: All quick disconnects should comply with the specifications. DO NOT use fuses instead of circuit breakers.**

## Connection Specifications

**IMPORTANT: Connection must be made by a qualified electrician using wiring diagram provided with machine, or according to accepted European Union standards.**

Connect machine to an individual branch circuit not shared with lighting or other equipment. Shield conductors in a liquid-tight or approved flexible conduit. Copper conductors of correct size must be installed in accordance with National Electric Code (NEC) or other applicable codes.

Use wire sizes indicated in the Electrical Specifications chart for runs up to 50 feet [15 m] . Use next larger size for runs of 50 to 100 feet [15 to 30 m] . Use two (2) sizes larger for runs greater than 100 feet [30 m] .

**IMPORTANT: For X voltage - To obtain 200-240V from a 200-240V source, connect L1 and L2. To obtain 220-240V from a 380-415V source, connect L1 and N. Refer to Figure 35 .**

	<b>DANGER</b>
<p><b>Electrical shock hazard will result in death or serious injury. Disconnect electric power and wait five (5) minutes before servicing.</b></p>	
W810	

## Circuit Breakers and Quick Disconnects

Single-phase machines require a single-phase inverse-time circuit breaker. Three-phase machines require a separate, three-phase inverse-time circuit breaker to prevent damage to the motor by disconnecting all legs if one should be lost accidentally. Refer to *North American Approval* and *CE Approval* sections for model-specific circuit breaker requirements.

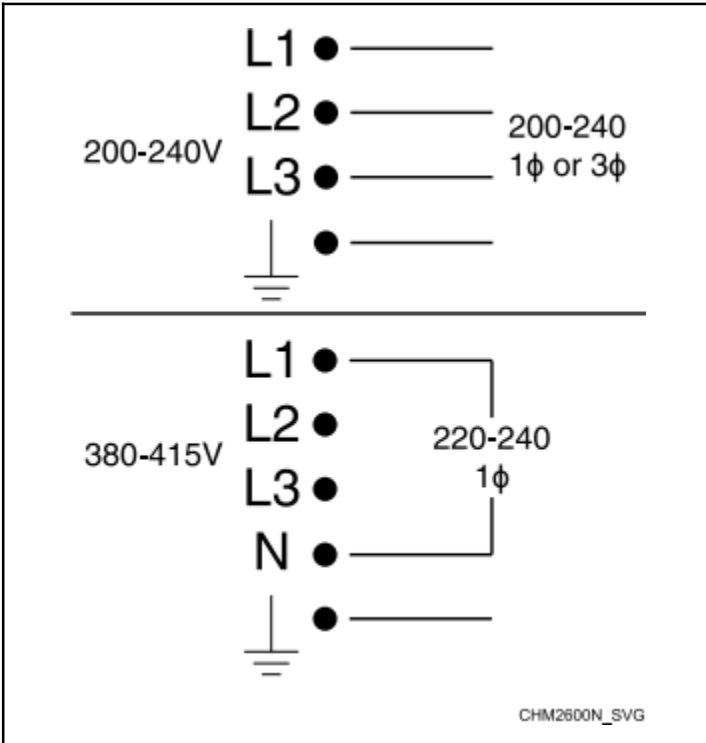

Figure 35

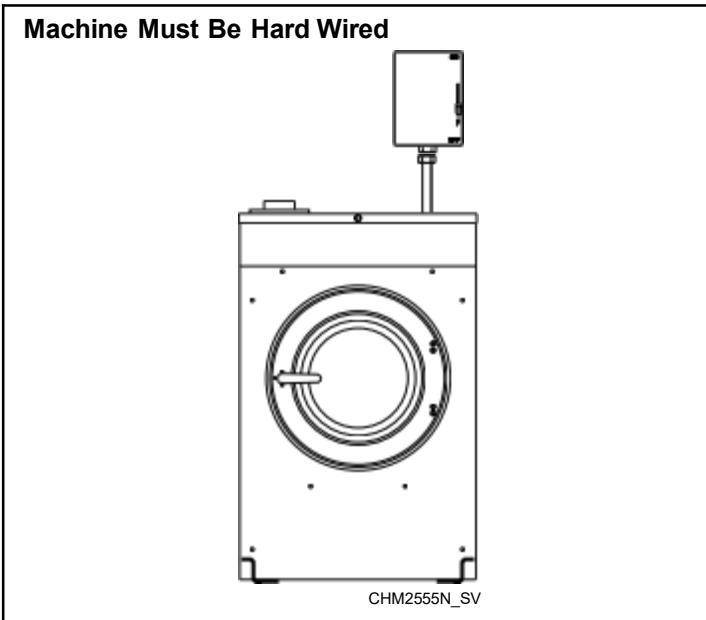

Figure 36

**IMPORTANT:** Where an emergency stop is required by local ordinances, a disconnect must be installed that is readily accessible to all users.

**NOTE:** Installation of models in North America: recommended installation is hard wired without a GFCI. If a GFCI is mandatory due to local requirements, then the GFCI must be rated for 30mA or higher.

**Single-Phase Connections**

For single-phase input, connect L1, L2 and Ground and cap neutral as shown in *Figure 37*.

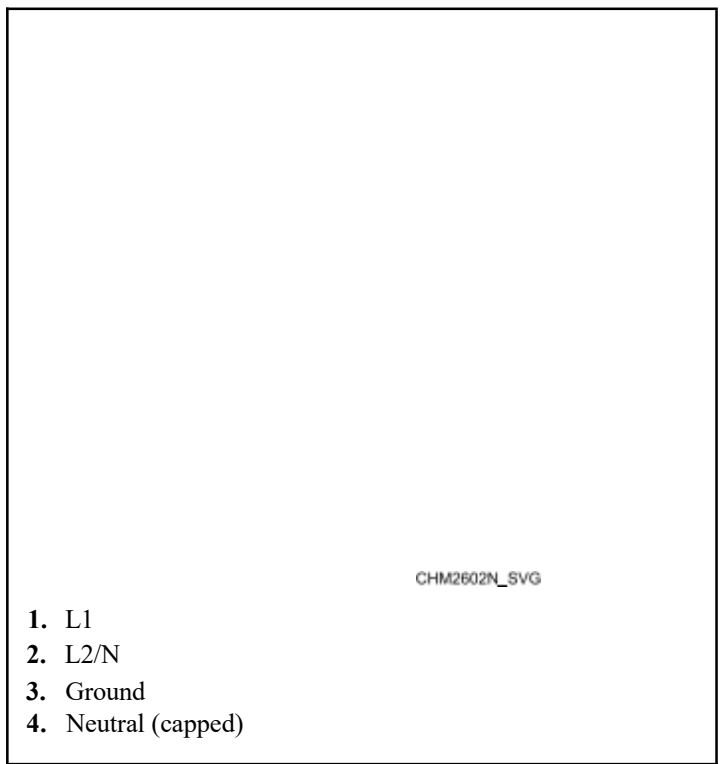

Figure 37

**NOTE:** Electrical receptacle must be located so that it is easily accessible with machine in place. An intermediate shut-off box with a 3 mm gap is required to meet EN 60335-1, clauses 24.3 and 22.2 or 3.5 mm gap is required to meet Standard IEC 60335-1, clauses 24.3 and 22.2. Gap is defined as the minimum contact separation of each pole in the switch between the “ON” and “OFF” positions.

### Three-Phase Connections

For three-phase input, connect L1, L2, L3 and Ground as shown in *Figure 38*.

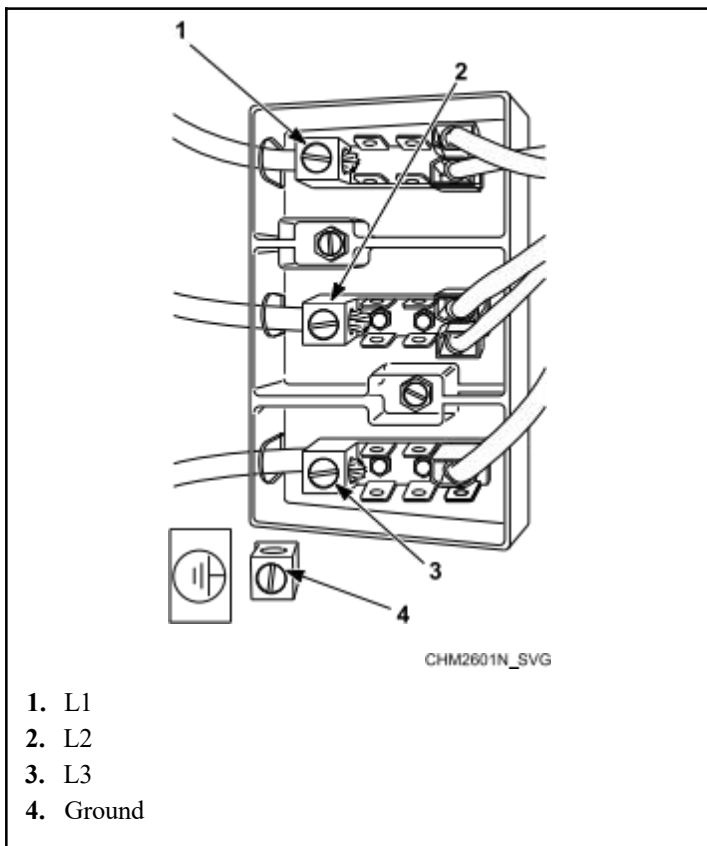

Figure 38

**Electrically heated machines DO NOT require dual power sources. Do not connect customer power or customer load to the Internal Load Distribution terminal block. Refer to the machine electrical schematic for details.**

W759

**IMPORTANT:** If a stinger leg is used for three-phase input, it **MUST** be connected to L3.

### Grounding

For personal safety and proper operation, the machine must be grounded in accordance with state and local codes. If such codes are not available, grounding must conform to the National Electric Code, article 250 (current edition). The ground connection must be made to a proven earth ground, not to conduit or water pipes.

	<b>WARNING</b>
--	----------------

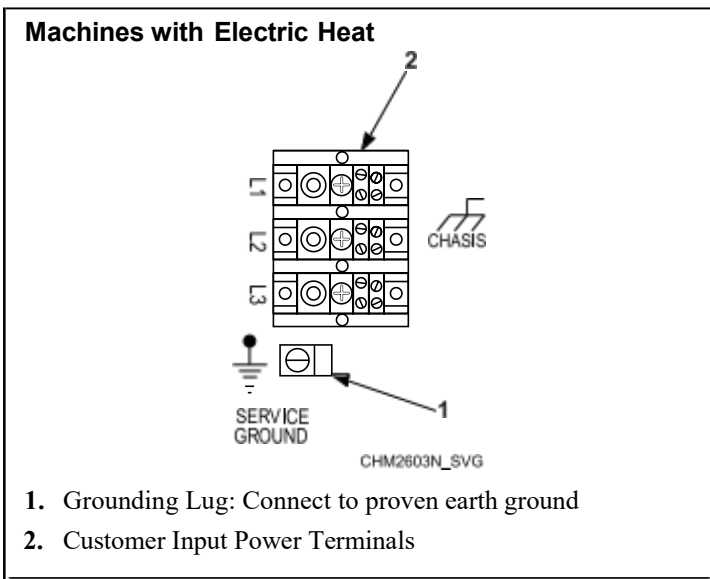

Figure 39

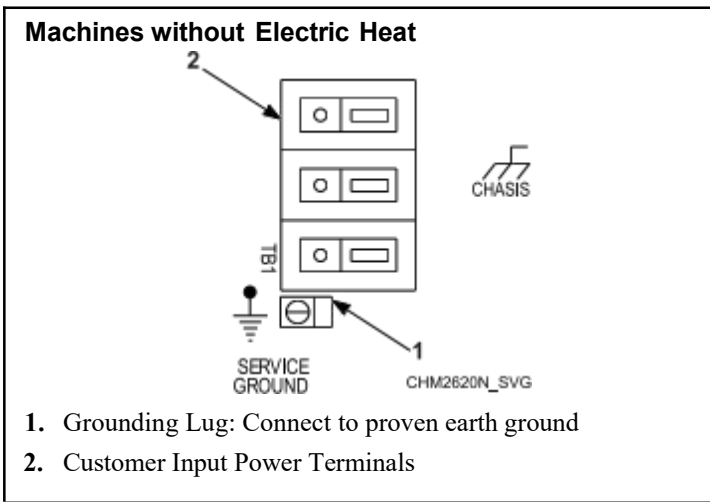

Figure 40

**Phase Adder**

**IMPORTANT: Do not use a phase adder on any machine.**

**Thermal Overload Protector**

The inverter drive provides overload protection for the drive motor.

60 Models - CE Approval								
Voltage Designation					Specifications			
Code		Voltage	Cycle	Phase	Wire	Full Load Amps	Circuit Breaker	mm <sup>2</sup>
<b>F-Speed Models</b>								
X		200-240	50-60	1/3	2/3	8/5	10/6	2.5
		220-240						
Q	Electric Heat	200-240	50-60	3	3	33- 39	50	10.0
P	Standard	380-415	50-60	3	3	4	6	2.5
	Electric Heat					23	32	2.5
N	Standard	440-480	50-60	3	3	4	6	2.5
	Electric Heat					20	25	2.5
<b>V-Speed Models</b>								
X		200-240	50-60	1/3	2/3	11/7	16/ 10	2.5
Q	Electric Heat	200-240	50-60	3	3	33- 39	50	10.0
P	Standard	380-415	50-60	3	3	4	6	2.5
	Electric Heat					23	32	2.5
N	Standard	440-480	50-60	3	3	4	6	2.5
	Electric Heat					20	25	2.5

Table 41

**Connection for Chemical Supply Hoses (refer to *Figure 42* for detail of chemical supply connector)**

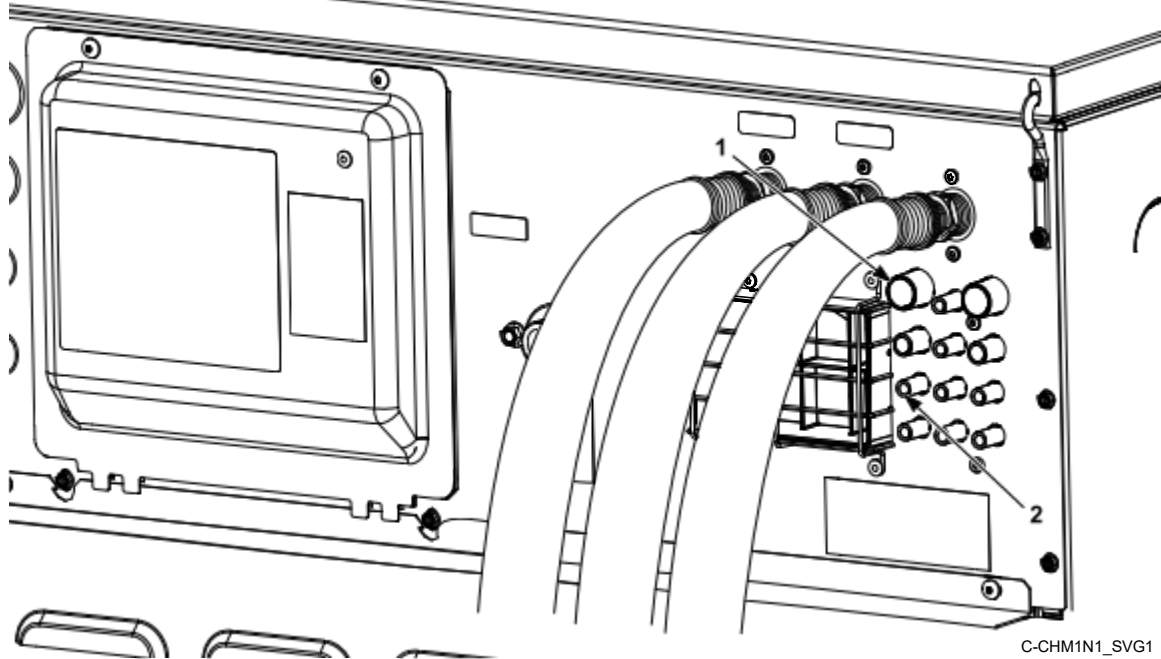

C-CHM1N1\_SVG1

- 1. Chemical Supply Connector
- 2. External Liquid Supply Connection Ports (12)

Figure 41

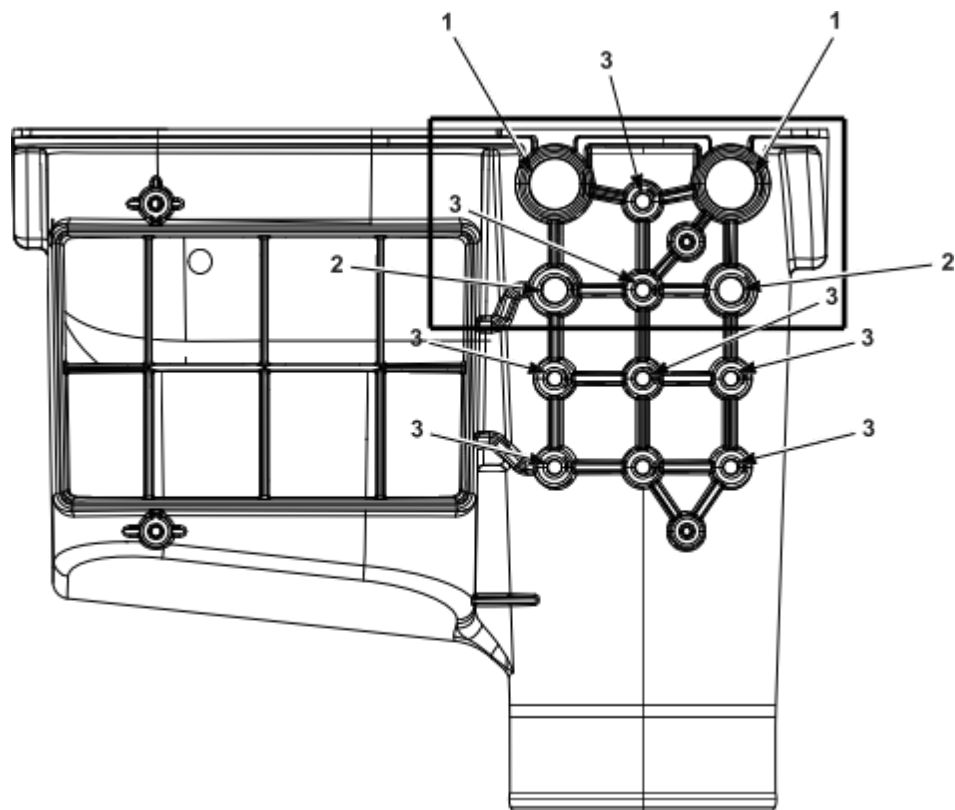
**External Liquid Supply Connection Ports**

C-CHM1N2\_SVG1

**NOTE: A flush manifold system can only be connected through the top 6 ports (boxed).**

1. 3/4 inch port, O.D.
2. 1/2 inch port, O.D.
3. 3/8 inch port, O.D.

Figure 42

### Chemical Supply Setup

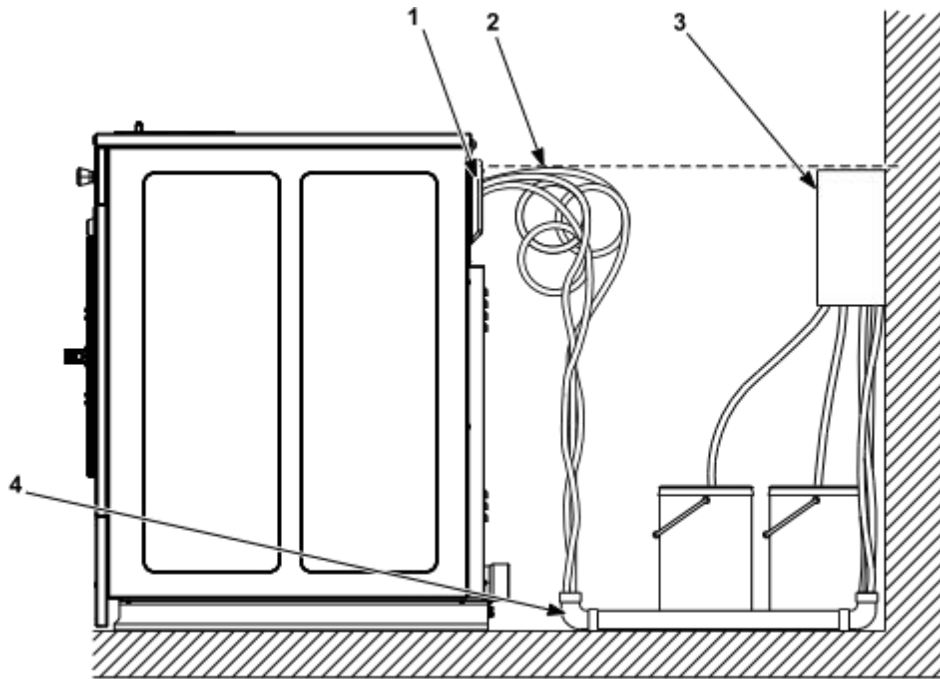

CHM2604N\_SVG1

\* Use a check valve on the end of tubing

† Pumps must be mounted below the injection point

1. Injection Point\*
2. Loops
3. Chemical Dispenser Pump Outlet †
4. PVC Pipe

Figure 43

# Start Up

## Basket Rotation

After installation is complete, run the machine through a test cycle and check that basket rotation is counter clockwise in the extract step.

1. If rotation is not counter clockwise, disconnect power to machine.
2. Have a qualified electrician reverse any two motor leads at the motor.

# Operation

## Operating Instructions

1. Turn on main power source (circuit breaker).
2. Turn handle clockwise to open. Refer to *Figure 52* .

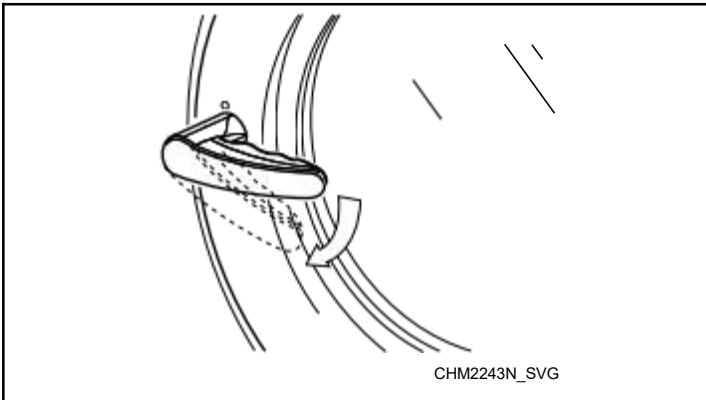

Figure 52

3. Load to capacity whenever possible. DO NOT OVERLOAD. Refer to *Figure 53* .

**NOTE:** Underloading can cause out-of-balance conditions that can shorten machine life.

	<b>CAUTION</b>
<p>Be careful around the open door, particularly when loading from a level below the door. Impact with door edges can cause personal injury.</p>	
SW025	

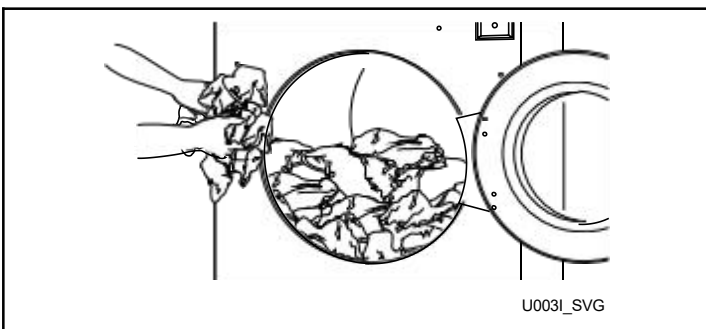

Figure 53

**NOTE:** When washing items which may disintegrate or fragment, such as mop heads or sponges, use laundry nets to prevent drain blockage.

**IMPORTANT:** To prevent out-of-balance conditions, premature wear or damage to machine when using laundry nets, use several small nets in a load.

4. Close the door and turn handle counter clockwise. Refer to *Figure 54* .

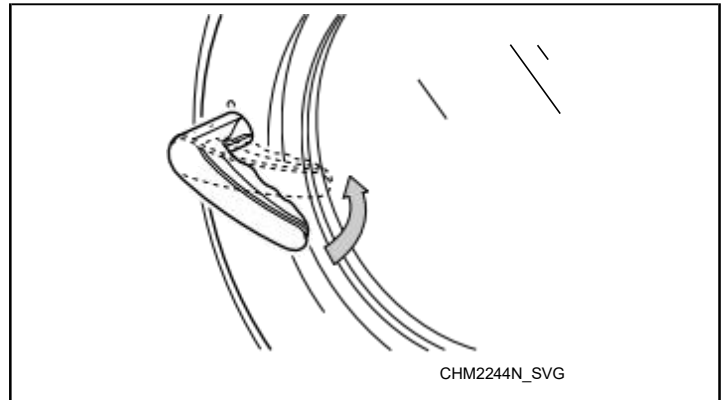

Figure 54

5. Refer to *OPL Control Instructions* to select and start a cycle.

	<b>CAUTION</b>
<p>Water cannot be extracted from rubber backed items. To avoid damage to machine from out of balance conditions, do not use a spin (extract) step when washing rubber backed items. Warranty will be voided.</p>	
W880	

	<b>WARNING</b>
<p>To prevent personal injury, avoid contact with inlet water temperatures higher than 125° Fahrenheit [51° Celsius] and hot surfaces.</p>	
W748	

# Maintenance

Routine maintenance maximizes operating efficiency and minimizes downtime. The maintenance procedures described below will prolong the life of the machine and help prevent accidents.

	<b>WARNING</b>
<p><b>Sharp edges can cause personal injury. Wear safety glasses and gloves, use proper tools and provide lighting when handling sheet metal parts.</b></p>	
W366R1	

	<b>CAUTION</b>
<p><b>Replace all panels that are removed to perform service and maintenance procedures. Do not operate the machine with missing guards or with broken or missing parts. Do not bypass any safety devices.</b></p>	
SW019	

Follow local codes for proper advise on laundering infected garments.

The following maintenance procedures must be performed regularly at the required intervals.

## Daily

**IMPORTANT: Replace all panels that are removed to perform maintenance procedures. Do not operate the machine with missing guards or with broken or missing parts. Do not bypass any safety devices.**

	<b>WARNING</b>
<p><b>Do not spray the machine with water. Short circuiting and serious damage may result.</b></p>	
W782	

**IMPORTANT: Door lock should be checked daily to ensure proper operation. Also check that all safety and instruction stickers are on the machine. Any missing or illegible safety instructions stickers should be replaced immediately.**

## Beginning of Day

1. Inspect the door interlock before starting operation.
  - a. Attempt to start the machine with the door open. The machine should not start.
  - b. Close the door without locking it and start the machine. The machine should not start.

- c. Attempt to open the door while the cycle is in progress. The door should not open.

If the door lock and interlock are not functioning properly, disconnect power and call a service technician.

2. Check the machine for leaks.
  - a. Start an unloaded cycle to fill the machine.
  - b. Verify that door and door gasket do not leak.
  - c. Verify that the drain valve is operating and that the drain system is free from obstruction. If water does not leak out during the first wash segment, the drain valve is closed and functioning properly.
3. Inspect the water inlet valve hose connections on the back of the machine for leaks.
4. Inspect the chemical connections for machines equipped with an automatic chemical supply system by inspecting all connections and chemical hoses for leaks or cracks.

	<b>WARNING</b>
<p><b>To reduce the risk of electrical shock, serious injury or death, disconnect the electrical power to washer-extractor before examining the wiring.</b></p>	
W636	

5. If applicable, inspect the steam hose connections for leaks.
6. Ensure all panels and guards are properly installed.

## End of Day

1. Clean the wash drum, door glass, and door gasket of residual detergent and all foreign matter.
2. Clean the chemical dispenser, flushing with clean water.
3. Clean the machine's exposed surfaces with all-purpose cleaner.

**IMPORTANT: Use only isopropyl alcohol to clean graphic overlays. DO NOT use ammonia based or vinegar-based cleans on overlays.**

**NOTE: Unload the machine promptly after each completed cycle to prevent moisture buildup. Leave loading door and dispenser lid open at the end of each completed cycle to allow moisture to evaporate.**

4. Leave the loading door and dispenser lid open to allow moisture to evaporate.

**NOTE: Unload the machine promptly after each completed cycle to prevent moisture buildup.**

5. Shut off water supply.

## Monthly



### WARNING

To reduce the risk of electrical shock, serious injury or death, disconnect the electrical power to washer-extractor before examining the wiring.

W636

1. Inspect the electrical connections for looseness. Tighten as required after disconnecting power.
  - a. Verify that insulation is intact on all external wires and that all connections are secure. If bare wire is evident, call a service technician.
2. Clean inlethose filter screens.
  - a. Turn water off and allow valve and water line to cool, if necessary.
  - b. Unscrew inlethose from the faucet and remove filter screen.
  - c. Clean with soapy water and reinstall. Replace if worn or damaged.
  - d. Repeat procedure with the filter located inside the valve at the back of the machine.

**NOTE: All filter screens should be replaced every five years.**

3. If applicable, clean the customer-supplied steam filter. Refer to *Figure 65*.
  - a. Turn off steam supply and allow time for the valve to cool.
  - b. Unscrew cap.
  - c. Remove element and clean.
  - d. Replace element and cap.

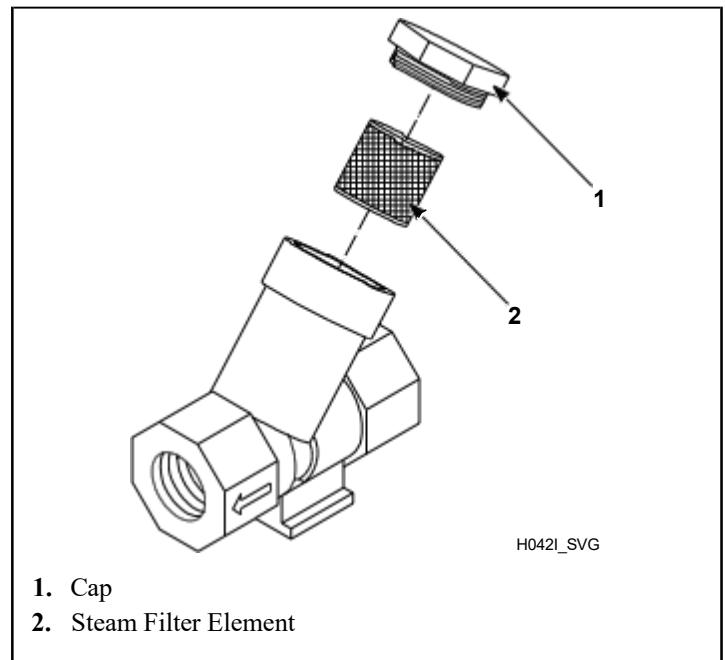

1. Cap
2. Steam Filter Element

Figure 65

4. For electric heat models only, inspect heating elements for excess debris by rotating basket to view them through its perforations. Remove drain valve hose to access and clear debris with pliers. Replace element(s) if necessary.

**NOTE: Lint buildup may take several months to occur. Inspect heating elements a minimum of every 6 months.**

5. **For 80 and 100 pound [36.3 and 45.4 kg] capacity models only** : Lubricate the barings each month or after every 200 hours of operation. Visually inspect grease line for air pockets, purging air pockets as necessary.

The grease must have the following characteristics:

- NLGI Grade 2
- Lithium-based
- Water-insoluble
- Anti-rusting
- Anti-oxidizing
- Mechanically stable

The grease must have adequate base oil viscosity with one of the following ratings:

- ISO VG 150 (709–871 SUS at 100°F [135–165 cSt at 40°C] )
- ISO VG 220 (1047–1283 SUS at 100°F [198–242 cSt at 40°C] )
- An SAE 40 rating is also acceptable as long as the cSt or SUS values are within the specified ranges.

Pump the grease gun slowly, permitting only 2 strokes.

**NOTE: Do not pump the grease gun until grease comes out of the bearing housing. This can result in over lubrication, causing damage to bearings and seals.**

**Yearly**

**NOTE: Disconnect power to the machine at its source before performing maintenance procedures.**

1. Remove the front panel(s) and rear access panels and inspect all hose, drain, and overflow connections/clamps for leaks. Inspect all hoses for visible signs of deterioration. Replace as necessary.
2. Inspect the belt for unusual wear, frayed edges, and improper belt tension, replacing belts and/or adjusting tensioning elements as necessary.

**NOTE: Belts must not be twisted and must be properly seated on pulleys. Belt must be centered on basket pulley within .04 inches [1 mm] .**

- a. Use the following procedures to determine if belt(s) require replacement or adjustment. Call a qualified service technician in either case.

**NOTE: Basket pulley must be rotated three (3) full turns before assessing belt tension after every adjustment.**

- **Frequency Gauge.** Tighten eyebolt top nut until the correct frequency (refer to *Table 47*) is obtained mid-span. Torque jam nut to spring bracket to  $20.6 \pm 2$  ft.-lbs. Refer to *Figure 66* .

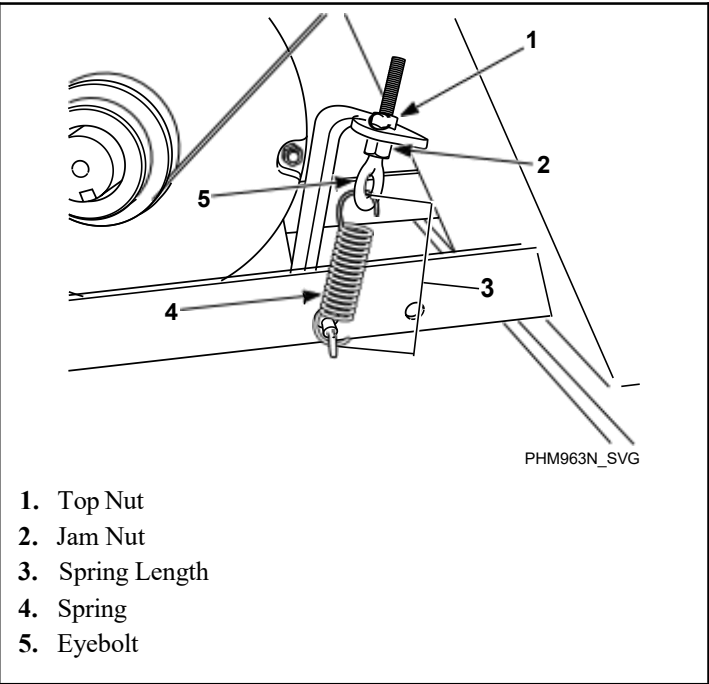

Figure 66

- **Tension Gauge.** Tighten eyebolt top nut until the proper belt gauge (refer to *Table 47*) is obtained mid-span.

Torque jam nut to spring bracket to  $20.6 \pm 2$  ft.-lbs. Refer to *Figure 66* .

- **Spring Length.** Tighten eyebolt top nut until the spring measures the correct distance between the hooks. Refer to *Table 46*. Torque jam nut to spring bracket to  $20.6 \pm 2$  ft.-lbs. Refer to *Figure 66* .

Spring Length, in. [mm]	
Model	Distance Between Hooks
20 (2 HP)	4-9/16 [116]
30	4-1/2 [114]
40	4-5/8 [117]
60	5-1/4 [133]

Table 46

- **Maintain Tension During Belt Removal.** If proper tension is achieved, tape the jam nut in place and loosen eyebolt top nut to release the belt. Replace belt and retighten eyebolt top nut back to jam nut position. Refer to *Figure 66* .

**IMPORTANT: All torque joints must remain dry (non-lubricated).**

- b. **20-60 Models:** verify the belt is centered on the basket pulley within one (1) rib. **80-100 Models:** verify the belt is within the allowable distance of .04 inch [1 mm] between the belt and the edge of basket pulley.

Belt Tension by Frequency or Belt Tension Gauge			
Model	Frequency (Hz)	Belt Tension (lbs.)	Tension Gauge (N)
20	$88 \pm 2$	$60.4 \pm 6.1$	$269 \pm 27$
30	$84 \pm 2$	$63.2 \pm 6.3$	$281 \pm 28$
40	$75 \pm 2$	$88.6 \pm 8.8$	$394 \pm 39$
60	$70 \pm 2$	$100.2 \pm 5.7$	$446 \pm 25$

Table 47

Remove any accumulated debris on or near the motor and motor variable frequency drive heat sinks, if applicable.

4. If applicable, unlock or unscrew the top cover and inspect the supply dispenser hoses and hose connections for visible signs of deterioration. Replace hoses if worn or damaged.

**NOTE: Hoses and other natural rubber parts deteriorate after extended use. Hoses may develop cracks, blisters or material wear from the temperature and constant high pressure they are subjected to.**

5. Remove any dust from all electrical components, including coin acceptors if applicable, with compressed air.

6. Inspect hardware for any loose nuts, bolts, screws.

a. Check the tightness of the motor spring and motor pulley hardware. Also check that the eyebolt is tightened properly.

b. Tighten motor mounting bolt locknuts and bearing bolt locknuts, if necessary.

c. Check the bearing mounting bolts to make sure they are torqued properly. Refer to *Table 48*.

Torque, ft-lbs.		
Model	Bearing	Torque
20	All	41
30-40	All	101
60	All	201
80-100	All	357

Table 48

- d. Tighten door hinges and fasteners, if necessary.
- 7. Place a large magnet over the normally-closed ball switch to verify the stability switch operation.
- 8. Ensure all panels and guards are properly reinstalled.
  - a. Verify that the drain motor shield is in place and secure, if so equipped.
- 9. Run factory test, reference programming manual for procedure details and components tested.

**NOTE: Refer to the Programming Manual for procedure details and components tested.**

- 10. Inspect all painted surfaces for exposed metal. Replace or repaint if necessary.
  - If bare metal is showing, paint with primer or solvent-based paint.
  - If rust appears, remove it with sandpaper or by chemical means. Repaint with primer or solvent-based paint.
- 11. Torque anchor bolts and inspect grout for cracking.

**NOTE: Refer to the Installation Manual for anchor bolt specifications.**

**IMPORTANT: All torque joints must remain dry (non-lubricated).**

- 12. Every 5 years replace inlet hoses, hose screens, belt, and fan filter (if applicable).

# KH18070HSA

commercial vended washer extractor controller

## Factory Manual

[Just for engineers!]









Read this manual carefully and become familiar with it before trying to install, operate or maintain it!

Model: KH18070HSA

Software version: DM18070HSA.TY.F01M V101  
LY014A.TY.B01M.V100HSA

**All rights reserved, do not copy without explicit permission.**

**The manual is subject to change without any prior notice.**

Installation		<ul style="list-style-type: none"> <li>● Please fix the controller to avoid vibrate drops。</li> <li>● Please install the controller in the metal or not inflammable board.</li> </ul>
		<ul style="list-style-type: none"> <li>● Please guarantee electric cabinet temperature among -10℃ ~+50℃, adding the ventilating fan when necessary.</li> <li>● Do not expose in the sunlight, strong airflow and mist</li> <li>● Do not expose in corrosive and pollution gas, such as sulfide gas, salt mist.</li> </ul>
Wiring		<ul style="list-style-type: none"> <li>● Please confirm the power supply is OFF.</li> <li>● Let the professional worker to wiring</li> <li>● Signal without source input, please do not connect with power supply,</li> <li>● <b>Please add the system protection, avoid the controller failure and cause dangerous situation.</b></li> </ul>
		<ul style="list-style-type: none"> <li>● Please observe the strong and weak electricity separation principle.</li> <li>● Please use the conforms to the technical standard wire</li> <li>● Please select the parallel method,</li> </ul>
Parameter		<ul style="list-style-type: none"> <li>● Do not intend to change parameter while Machine is running.</li> </ul>
Run		<ul style="list-style-type: none"> <li>● After confirming the wiring correctly, then power on.</li> <li>● Guarantee environmental condition and the power supply voltage is In permit condition, only in this way can start the machine.</li> <li>● When running, please do not inspect the signal.</li> <li>● When running, please do not change the parameter setting.</li> <li>● When running, please do not approach the machine.</li> </ul>
Maintenance, inspection	 	<ul style="list-style-type: none"> <li>● The user has any repair needs, please contact with manufacturer, do not intend to repair it by yourself.</li> <li>● Please do not pull, twist the power line and communication line.</li> <li>● Please do not touch the controller device directly.</li> </ul>
Others		<ul style="list-style-type: none"> <li>● Please be careful when simulating and adjusting the controller on The desk. Presence of high voltage could cause electrical hazard</li> </ul>

# Content

<b>1 PRODUCT OVERVIEW .....</b>	<b>1</b>
<b>2 ELECTRIC SCHEMATICS .....</b>	<b>2</b>
2.1 Electric wiring dirgram .....	2
2.1.1 LY014A electric wiring diagram .....	2
<b>3 INTERFACE AND MENU TREE .....</b>	<b>3</b>
<b>4 INTERFACE INTRODUCTION .....</b>	<b>4</b>
4.1 System check after power on .....	4
4.2 Top menu .....	4
4.3 User log in .....	4
4.4 Formula edit(Formula selection) .....	5
4.5 Formula edit (Formula details edit) .....	6
4.6 Idle page and auto running page .....	6
4.6.1 Idle page .....	6
4.6.2 Payment interface .....	6
4.6.3 Auto running page .....	7
4.6.4 Auto running complete .....	7
4.7 Alarm page .....	7
4.8 Parameter setting page .....	8
4.9 Power on .....	8
4.10 Idle page .....	8
4.11 Lock the door .....	8
4.12 Unlock the door .....	8
<b>5 FORMULA EDIT INSTRUCTIONS .....</b>	<b>9</b>
5.1 Flowchart of formula edit .....	9
5.2 Creat a new formula .....	10
5.2.1 Select an empty formula .....	10
5.2.2 Creat a new step .....	10
5.2.3 Step type selection .....	10
5.2.4 Select the step actions and step parameters .....	11
5.2.5 Modify step details in an existing step .....	11
5.2.6 Insert an new step in front of the selected step .....	12
5.2.7 Copy a selected step to the step after the last step .....	12
5.2.8 Move the selected step .....	13
5.2.9 Delete the selected step .....	13
5.2.10 Save the formula .....	13
5.2.11 Escape from formula edit page .....	13
5.3 Edit an exsisting formula .....	14
5.3.1 Select an existing formula .....	14
5.3.2 Formula edit .....	14
5.3.3 Escape from formula edit page .....	14
5.4 Delete an exsiting formula .....	14
5.5 Copy selected formula to target formula .....	14
<b>6 PARAMETER SETTING .....</b>	<b>15</b>
6.1 Discount .....	23
6.2 Parameter initialization .....	24
6.2.1 Data transfer via USB drive .....	24
6.3 Update software via USB drive .....	24
6.4 USB functions alarms .....	24
<b>7. ALARM .....</b>	<b>25</b>
7.1. Alarm Reset .....	25

7.1.1. Alarm Information and Obviation ..... 26

# 1 Product overview

## Operation panel HM18070HSA:



**KH18070HSA is a controller especially designed for commercial vended washer extractors. It is composed of industrial control board LY014A and operation panel HM18070HSA. Industrial control board is designed for industrial laundry equipments. The operation panel is 7 inch colorful touchscreen which makes the parameter setting and programming so easy. The big buttons and big font words display makes the operation very friendly.**

### Features:

- Industrial control board: stable, reliable, safe and trustable;
- Industrial touch panel, high performance;
- 7 inch industrial colorful touchscreen, beautiful and high end;
- Pressure sensor detects the water level, very accurate;
- Formulas and parameters can be downloaded and uploaded via USB drive;
- Software can be updated via USB drive;
- Waterproof keys, long lifetime.

### Functions:

- auto, formula edit, diagnosis, user login;
- USB functions;
- Touch screen operation;
- digital output to control inverter;
- Step jump (Rapid advance);
- Cool down function;
- Imbalance protection function;
- Password protection;
- I/O diagnosis;
- Multiple languages;
- Coin statistics;
- Coin drawer full remind;

## 2 Electric schematics

### 2.1 Electric wiring diagram

#### 2.1.1 LY014A electric wiring diagram

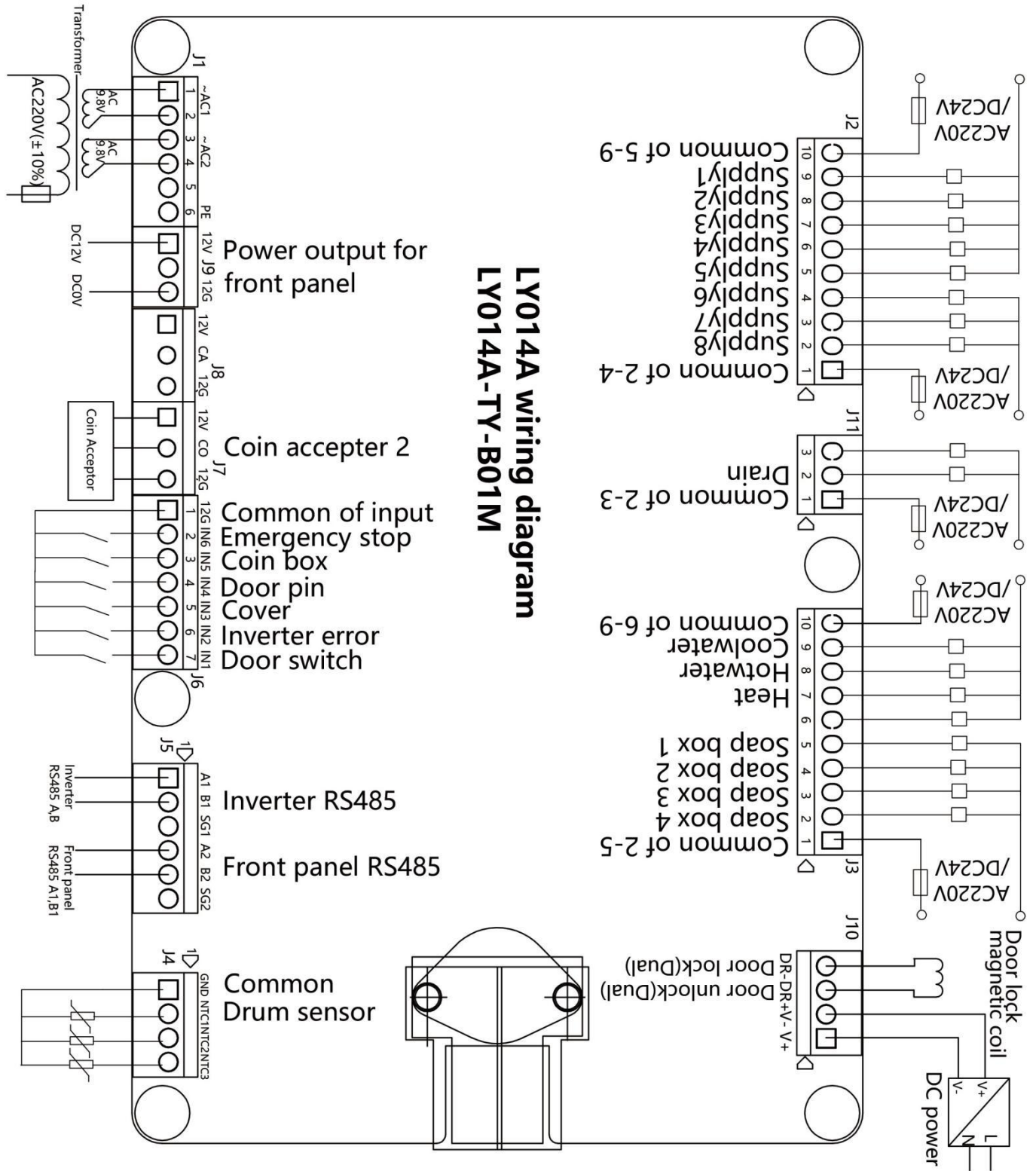

### 3 Interface and menu tree

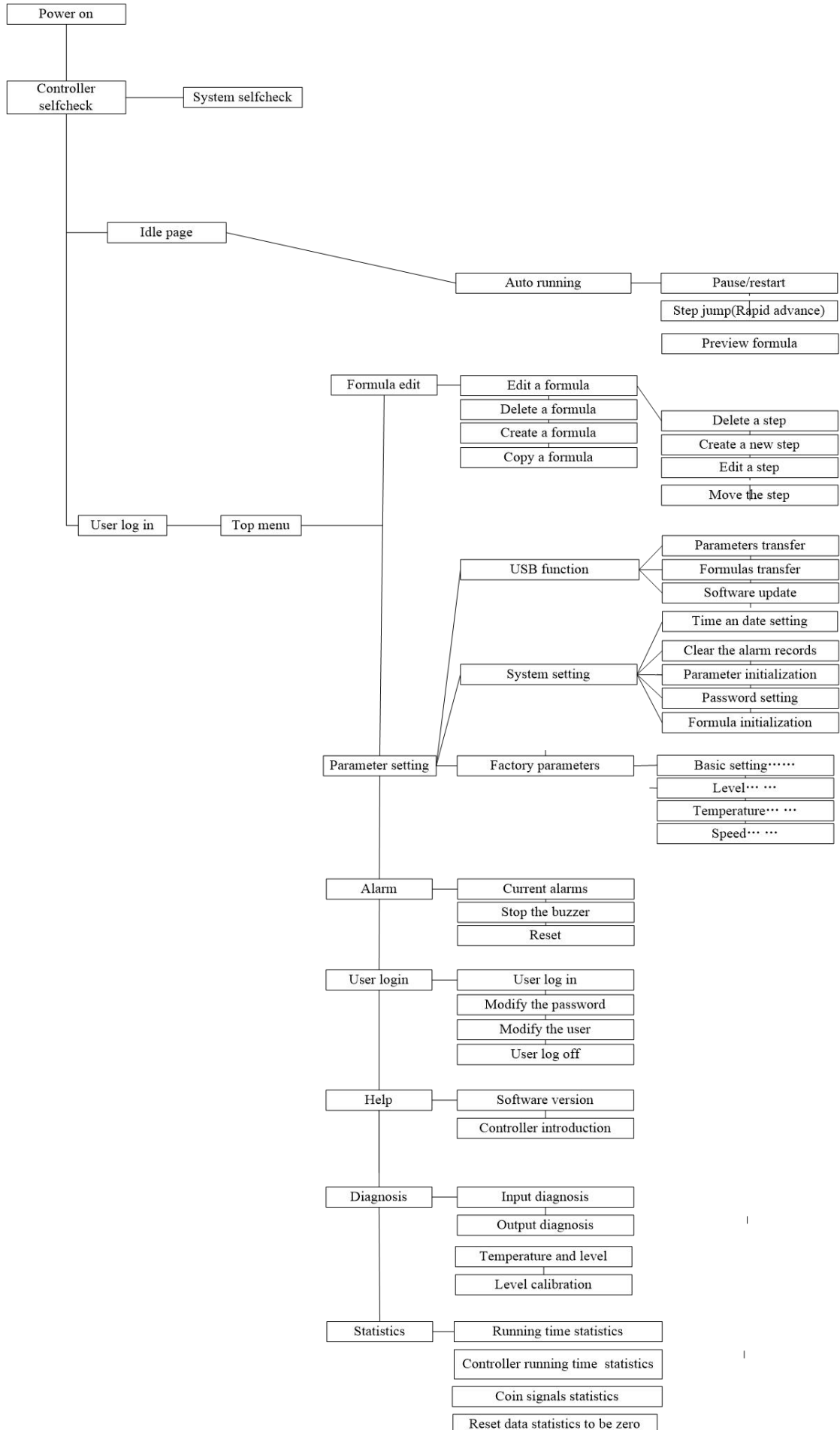

## 4 Interface introduction

### 4.1 System check after power on

Once power on, the controller enter selfcheck process:

- 1、 Match the models of touch panel and control board LY014A ;
- 2、 Check operation system Windows CE.

The controller will go to the operation page (idle page) after selfcheck succesfully. Otherwise, there is system error information displayed if selfcheck failure.

### 4.2 Top menu

Only user administritor or factory administrator can enter this page.



In top menu, operations available as below:

- 1、 Press“Coin acceptor clear” to reset the datas to be zero;
- 2、 Press“Login” to log in as one user.The default user is operator if not log in;
- 3、 Press“Alarm” to see the current alarms;
- 4、 Press“Diagnosis” to check the inputs,outputs,level,temperature and communication;
- 5、 Press“Help” to see help information such as software version;
- 6、 Press“Auto” to enter auto operation ;
- 7、 Press“Formula edit” to edit the formulas;
- 8、 Press“Parameter setting” to set factory parameters or user parameters, transfer datas via USB drive such as software update, parameters upload, parameters download.

### 4.3 User log in

After power on, in the page as below, press the topleft corner of the touchscreen once and you can hear a beep which remind you that you have pressed successfully.

Wait a few seconds, log in page displays and user can choose a user to log in. (shown as below)

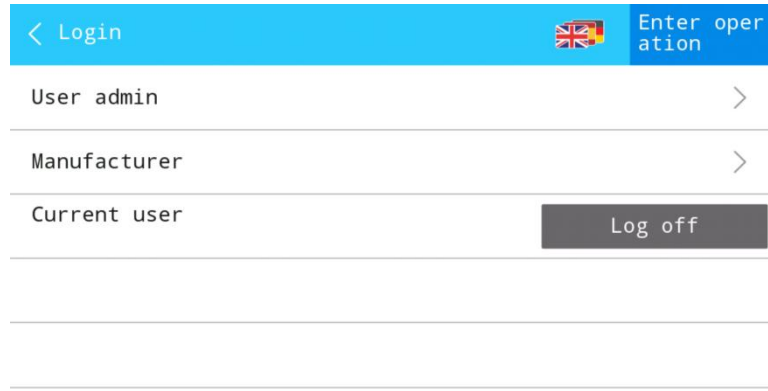

- 1、 Select a user to log in. Here are 2 user available, user administrator and factory.
- 2、 Please enter the passwords;
- 3、 Press “enter idle page” to enter the operation page;
- 4、 After log in successfully,user can change the language in this page;
- 5、 User can modify the passwords in this page,user must remember the new passwords.

**Note: Default passwords**

User	Default passwords
User administrator	123
Factory	456

#### 4.4 Formula edit(Formula selection)



**In top menu, press<Formula edit> to enter formula edit page.:**

- 1、 Select a formula needed to be edit;
- 2、 Here are 14 formulas available;
- 3、 Formula number,formula name and total time will be displayed; The total time will be 00:00 if this formula is an empty one;
- 4、 Formula edit, including step edit, copy selected formula to a target formula number, delete a formula, save formula ;
- 5、 Step details such as time and temoerature setting can be displayed during edit.

### 4.5 Formula edit (Formula details edit)

After user has selected a formula, enter the formula details edit page. User can operate as below:



- 1、 Step edit: enter step details edit page;
- 2、 Delete formula: empty the step details of the selected formula;
- 3、 Copy formula: Copy step details of selected formula to a target formula;
- 4、 Save formula: Save the modification of the formula.

### 4.6 Idle page and auto running page

#### 4.6.1 Idle page

In idle page, press P1~P15 to select a formula, press the payment button. There are 4 formulas to choose in this interface. The formula has the displayed price. Press the < disinfection > key to disinfect, The disinfection formula is P14.

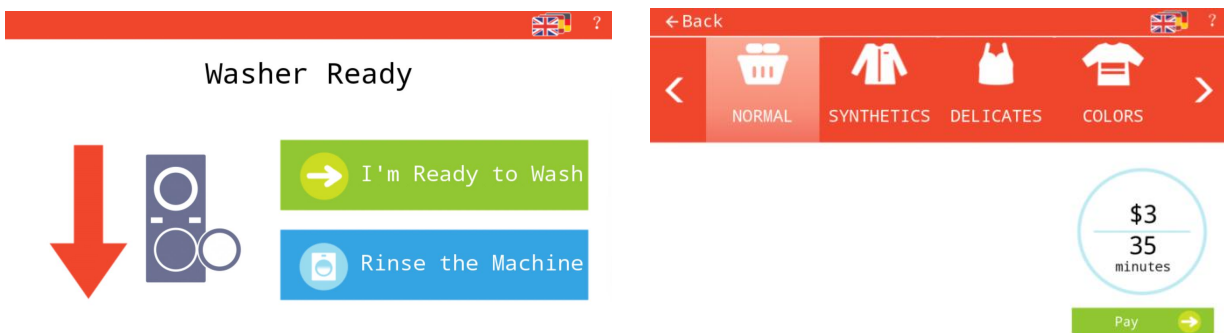

#### 4.6.2 Payment interface

This interface displays the total running time, the price to be paid. After the payment, if the door has been closed, you can press the key to run the machine.

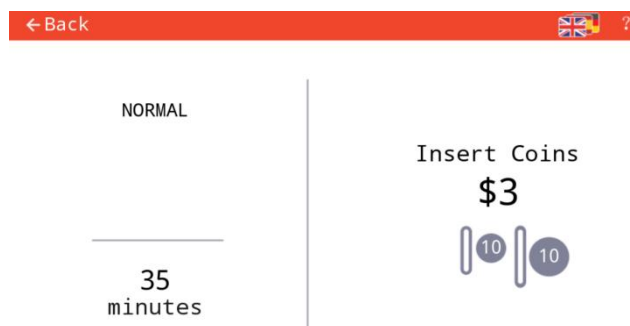

### 4.6.3 Auto running page

After pressing start, enter this page:

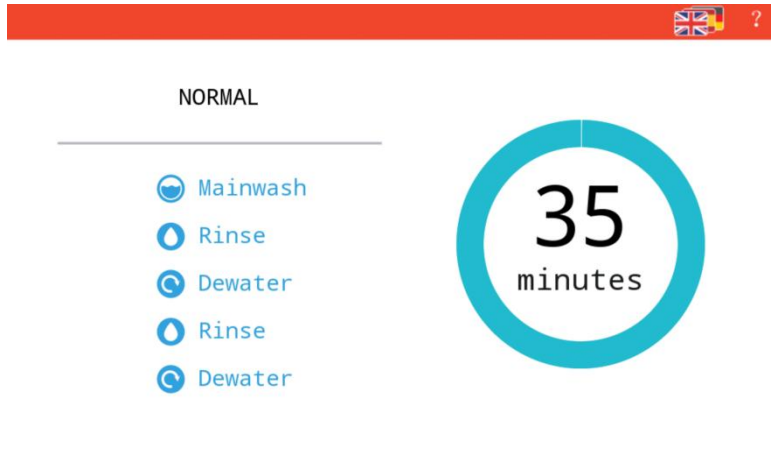

The information displayed :

- 1、 Remaining time;
- 2、 Step display: Current step name;

### 4.6.4 Auto running complete

Once the auto running process completed, buzzer rings to remind the operator to open the door and unload the clothes. The buzzer stops once the door open and enter the idle page automatically.



### 4.7 Alarm page

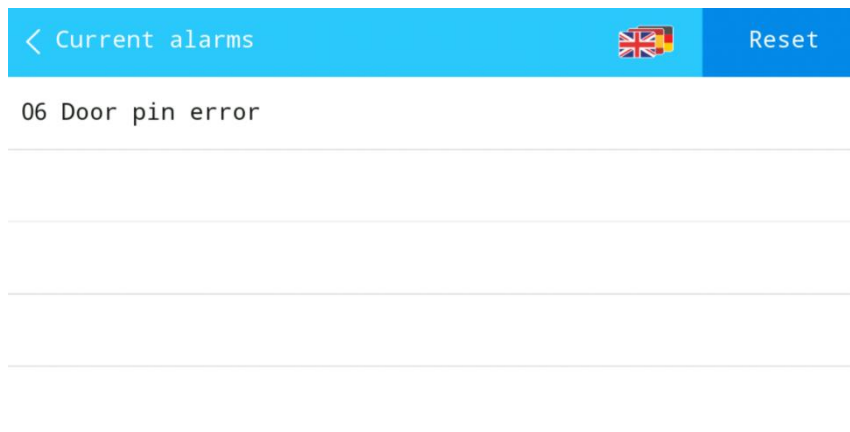

**This page will display once a error occurs.**

**Alarms information as below:**

**1、 List of current alarms;**

**2、 <Reset>:**

**Reset the alarms. The alarm information will still be displayed if error not resolved. User can press start to continue running if error has been resolved;**

**3、 <Home page>:**

**Escape to home page.**

## 4.8 Parameter setting page

**Parameters can be modified if user log in successfully as user administrator or factory.**



**1、 Parameter setting: enter factory setting;**

**2、 System setting: parameter initialization, formula initialization;**

**3、 Date transfer: upload or download the parameters and formulas via USB drive;**

**4、 software updation: update the software via USB drive;**

**5、 <Home>: Escape to top menu.**

## 4.9 Power on

**Once power on, the LCD will light and enter the idle page after selfchecking process.**

## 4.10 Idle page

**In this page, operator can select an desired formula and insert coins to start the selected formula.**

## 4.11 Lock the door

**The door will be locked automatically after start the formula.**

## 4.12 Unlock the door

**The door lock will be unlocked automatically while formula is completed.**

**Press "RAPID ADVANCE" key to unlock and open draining valve while machine alarm.**

**NOTE: This key is invalid while temperature high or level high.**

## 5 Formula edit instructions

In top menu, press <formula edit> to enter formula edit page. Here are 6 auto formulas available (Formula number is 1~6), 20 steps can be edit for one formula.

### 5.1 Flowchart of formula edit

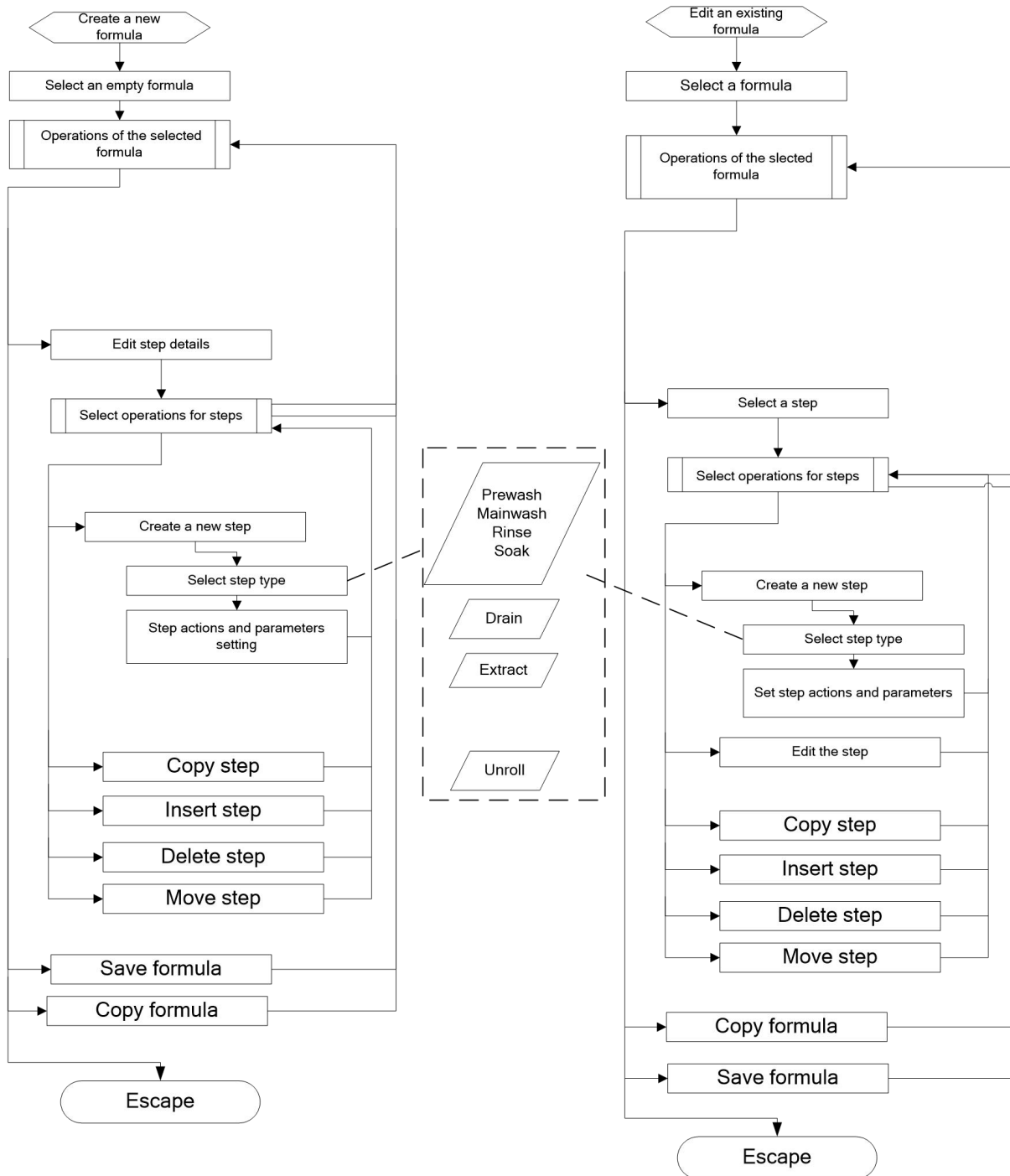

User can select an empty formula or an existing formula to edit.

Operations for a selected formula include copy, paste, delete, save and edit.

Operations for step edit include creating a new step, edit, copy, insert, delete, move up, move down.

## 5.2 Create a new formula

### 5.2.1 Select an empty formula

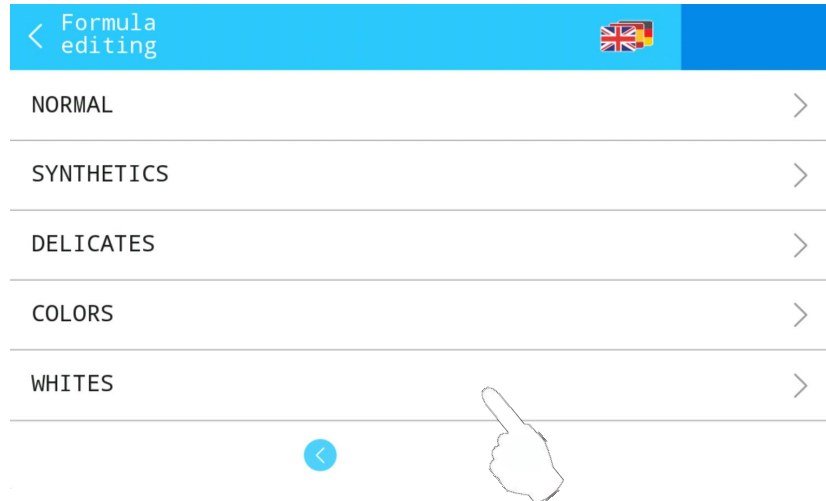

- 1、 Press<Formula edit> to enter formula selection page, shown as above.
- 2、 The total time will be 00:00 if it is an empty formula.

### 5.2.2 Create a new step

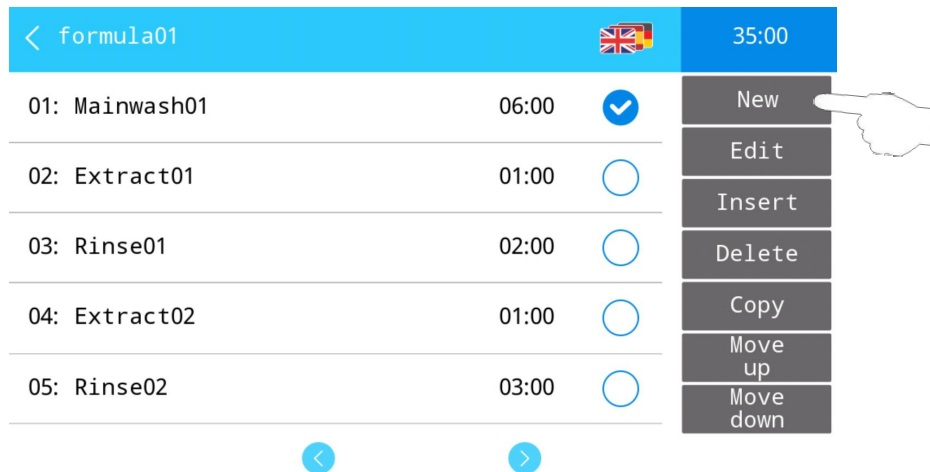

- 1、 Press<Step edit> to enter step details edit page;
- 2、 Press<New> to enter the step type selection page, shown as chapter 6.2.3 as below;
- 3、 The new step will be created following the current last step. For example, if the current last step is step 3, the newly created step will be step 4.

### 5.2.3 Step type selection

Step type selection page as below:



7 different step types can be selected: prewash, wash, rinse, soak, drain, extract, unroll. User can design the desired formula step details as needed.

Enter the step details edit page after selected a step type.

#### 5.2.4 Select the step actions and step parameters



Active function buttons and set value of time,level, temperature and speed.

#### Note:

- 1) Details of different step types are different, set the corresponding value and actions as you require;
- 2) Yellow color on buttons means active, white color on buttons means inactive;
- 3) Each step type has a default actions and setting values, modify some or all of them as you require.
- 4) "1prewash 1" means the current step number is 1, and the 1<sup>st</sup> prewash.
- 5) If you want to select the step type again, you can enter the 1<sup>st</sup> page and press "step type" to re-select the step type.

#### 5.2.5 Modify step details in an existing step

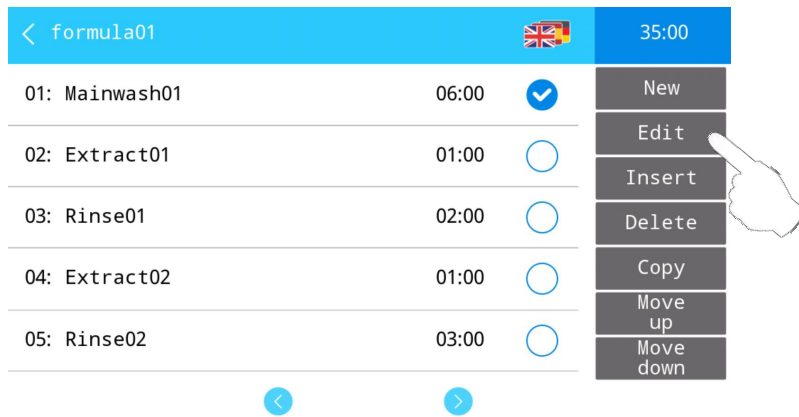

- 1、 Each existing step details are displayed ,press one step you want to modify and there will be a “hand” displayed on the left of this step. Then press “edit” to enter the step details edit page.
- 2、 The operations method is the same as creating new step;

### 5.2.6 Insert an new step in front of the selected step

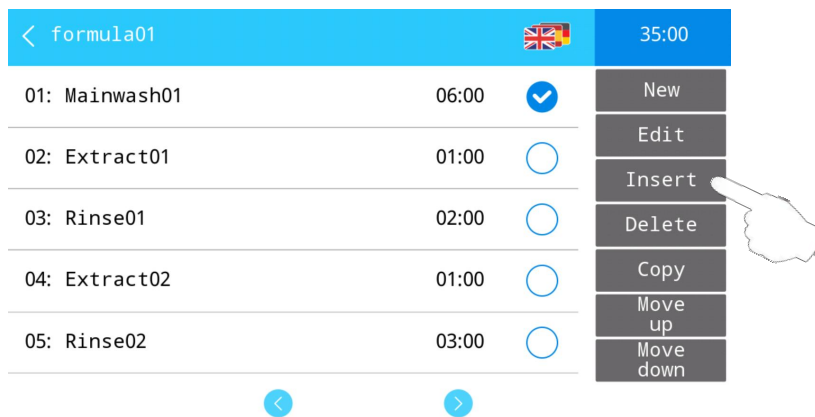

1. Select a step number before which a new step needs to be inserted. There will be a “hand” displayed on the left of this selected step
2. Step 02 is selected as above, there is a “hand” displayed on the left of this step;
3. Press “insert” to insert a new step before selected step and edit the details of the newly inserted step.

### 5.2.7 Copy a selected step to the step after the last step

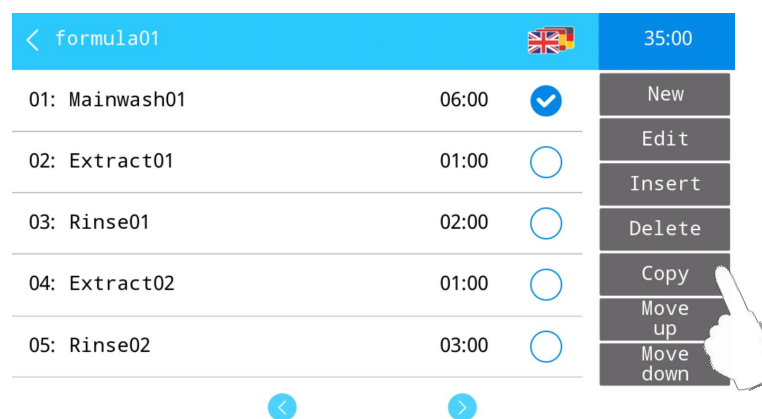

1. Select a step which you want to copy. There will be a “hand” displayed on the left of this selected step

2. Press “copy” to copy the selected step to the position behind the current last step.
3. As above, step 02 is selected. The current step is step 03. After pressing “copy”, step 02 is copied to step 04.

### 5.2.8 Move the selected step

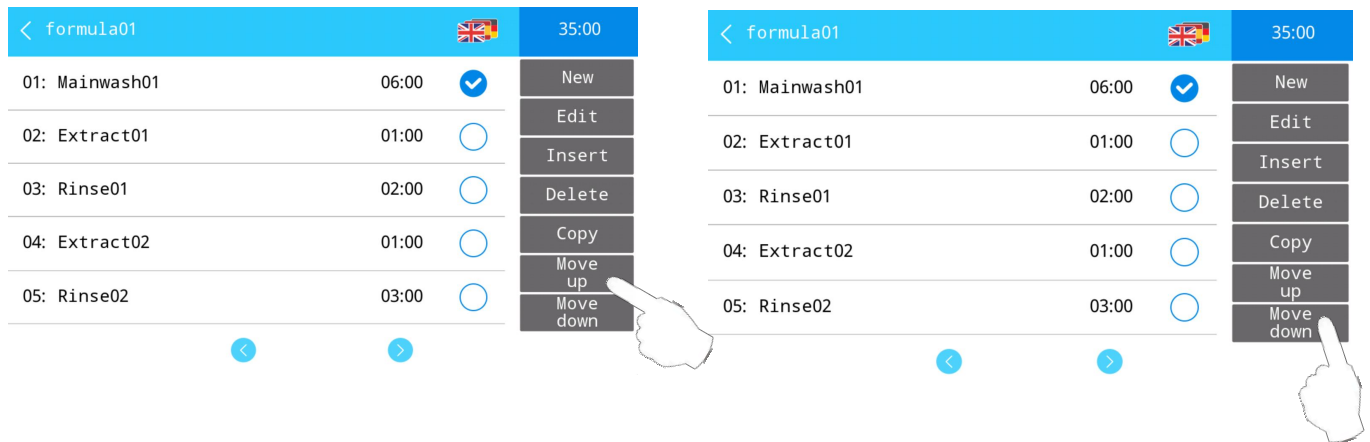

If user wants to adjust the position of the step, “move up” and “move down” can realize this function.

1. Press “move up” to move the selected step to the position of previous step. That means exchanging the positions of the selected step and the previous step. For example as above, the selected step is step 02, after pressing “move up”, the positions of step 02 and step 01 are exchanged.
2. Press “move down” to move the selected step to the position of following step. That means exchanging the positions of the selected step and the following step. For example as above, the selected step is step 02, after pressing “move down”, the positions of step 02 and step 03 are exchanged.

### 5.2.9 Delete the selected step

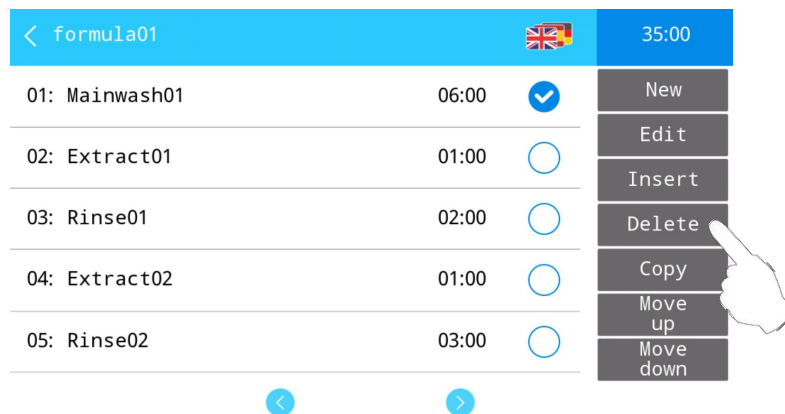

User can delete a step not needed.

Select the step you want to delete, press “delete” to delete the selected step. The steps behind the deleted step will move one step ahead.

### 5.2.10 Save the formula

After finishing the steps edit for the formula, press “back” to return to the operations for formula. As above, press “save” to save all of the modifications for this formula.

### 5.2.11 Escape from formula edit page

After saving the formula modifications, press “Back” to return to the formula selection page. Press “Home” to escape to top menu.

If user forget to press “save” to save the modifications, controller will remind user to save it or cancel the modifications.

### 5.3 Edit an existing formula

#### 5.3.1 Select an existing formula

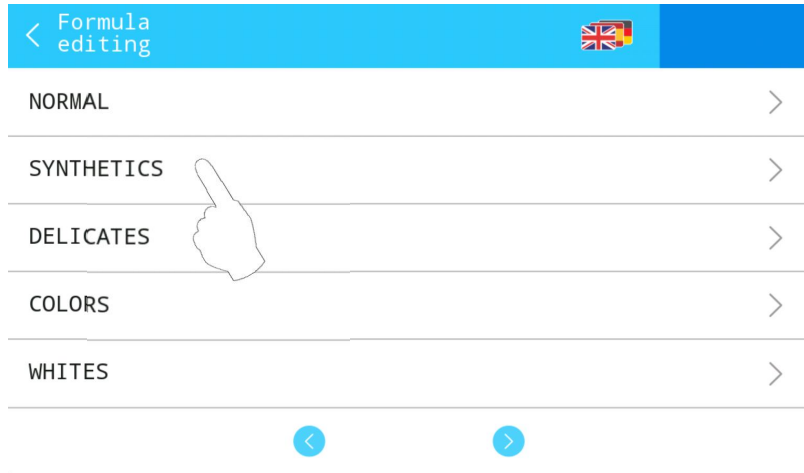

In formula selection page, select the existing formula need to modify.

#### 5.3.2 Formula edit



In fomula operations page, user can edit, copy ,delete and save the formula. The operation method is the same as a new formula explained as the previous chapter.

#### 5.3.3 Escape from formula edit page

Operation method is the same as escape from a newly formula edit page as explained in the previous chapter.

### 5.4 Delete an exsiting formula



After selecting a formula need to be deleted, press“Delete” ,controllfer reminds user to confirm the delete. The selected formula will be delete if user confirm this operation.

### 5.5 Copy selected formula to target formula

User can copy a formula to another target formula.

**After selecting a formula need to be copied, press “Copy” and then select the target formula number to copy selected formula to the target formula.**

<a href="#">&lt; formula01</a>		Confirm
Please enter the target formula number:		<input type="text" value="6"/>
<hr/>		
<hr/>		
<hr/>		
<hr/>		

## 6 Parameter setting

Group	Items	Default	Range	Introduction	Level
1: Machine function set	1:Machine capacity	100KG	1~200KG		Factory
	2:Drum Diameter	1000mm	0~9999mm		End User
	3:Temperature units	Celsius	Celsius, Fahrenheit		End User
	4:Auto drain	None	None, Door opened, Idle	None: don't open drain automatically. Door opened: open drain automatically while door opened Idle: open drain automatically while idle	Factory
	5:Drain valve status	N.C	N.C.,N.O.	Open: Drain valve is opened while draining. Close: Drain valve is closed while draining.	Factory
	6:Operate when running	YES	No, Yes	Allow change the level, temperature and action when auto running.	End User
	7:Skip step when running	No	No, Yes	When "operate when running" is set to "yes" and this item is set to "yes", you can skip to the next or above step by pressing [Up] or [Down] button.	End User
	8:Count time after heat	YES	No, Yes	Wash time without heat time, must reach temperature.	End User
	9:Require lubrication	3	0~9999 times	When the times of run reaches this value, it will prompt information of adding lubrication under door open status. The times of run can be browsed and be cleared by pressing [Extract] button for 3 seconds from startup screen.	Factory
	10:LOGO	Self-defined	Self-defined, Default	Startup interface.	Factory
	11:Count time after fill	Yes	No, Yes	Wash time without fill time, must reach water level.	End User
	12:Use the door pin	No	No, Yes	Door pin is used for door lock. If can't get the door pin input signal in time when locking, controller will alarm.	Factory
	13: Use O3	No	No, Yes	Disinfect with ozone.	
	14:Prog End Prompt	30	1~255	Time of prompt sound after washing.	Factory
2: Input status setup	1:Door closed	N.C	N.C.,N.O.	Open: Door closed when input signal is invalid. Close: Door closed when input signal is valid.	Factory
	2:Inverter error	N.C	N.C.,N.O.	Open: Inverter error when input signal is invalid. Close: Inverter error when input signal is valid.	Factory

	3:Extract shock	N.C	N.C.,N.O.	Open: Extract shock when input signal is invalid. Close: Extract shock when input signal is valid.	Factory
	4: Door pin closed	N.C	N.C.,N.O.	Open: Door pin closed when input signal is invalid. Close: Door pin closed when input signal is valid.	Factory
	5: Emergency	N.C	N.C.,N.O.	Open: Emergency when input signal is invalid. Close: Emergency when input signal is valid.	Factory
3:Fill and level setup	1:Zero level	0cm	0~99cm	Set the relative zero level.	Factory
	2:Low level	20cm	0~Middle Level	Set the low level for manual or auto run.	End User
	3:Middle level	30cm	Low Level~High Level	Set the middle level for manual or auto run.	End User
	4:High level	40cm	Middle Level~Overbrim Level	Set the high level for manual or aut run.	End User
	5:Overbrim level	90cm	High Level~99cm	Set the overbrim level. Drain valve will open when water higher than the overbrim level.	End User
	6:Auto re-fill when low	Yes	No, Yes	Auto re-fill when level is lower than set value.	End User
	7:Level diff. of re-fill	4cm	0~99cm	Auto re-fill when difference between current and set is larger than level difference of re-fill.	End User
	8:Max time of fill	10 Min	0~255 Min	If level is also lower than set value in time, controller will alarm.	End User
	9:Safety level of hot	10cm	0~99cm	Auto fill cold water when level is lower than safety level while filling hot water.	End User
	10:Hot fill intellective	Yes	No, Yes	Fill hot water or cold water intellective to reach set temperature value.	End User
	11:Level to stop	0	0~100cm	When the machine reaches [Liquid level setting value - Level to stop], the drum stops rotating to make the liquid level more accurate.	End User
	1:Min water temperature	0℃	0~Max Temperatrue	The min value of water set temperature.	End User
	2:Max water temperature	90℃	Min Temperatrue~99℃	The max value of water set temperature	End User

4:Heat and temp. setup	3:Temperature of heat	70℃	Min Temperatrue~M axTemperatrue	The default value of temperature of heat	End User
	4:Auto re-heat when low	Yes	No, Yes	Auto re-heat when temperature is lower than set value.	End User
	5:Temp. diff. of re-heat	4℃	0~99℃	Auto re-heat when difference between current and set is larger than temperature difference of re-heat.	End User
	6:Max time of heat	10 Min	0~255 Min	If temperature is also lower than set value in time, controller will alarm.	End User
	7:Safety level of heat	10cm	0~100cm	Auto fill cold water when level is lower than safety level while heating.	End User
5:Soap setup	1: Soap stop filling	Yes	No, Yes	Stop fill cold water while soaping to avoid low water pressure.	End User
	2: Safety level of soap	10cm	0~99cm	Auto fill water when level is lower than safety level while soaping.	End User
	3:Set time of soap 1	30 Sec	0~255 Sec	Default set time of soap 1.	End User
	4:Set time of soap 2	30 Sec	0~255 Sec	Default set time of soap 2.	End User
	5:Set time of soap 3	30 Sec	0~255 Sec	Default set time of soap 3.	End User
	6:Set time of soap 4	30 Sec	0~255 Sec	Default set time of soap 4.	End User
	7:Set time of soap 5	30 Sec	0~255 Sec	Default set time of soap 5.	End User
	8:Set time of soap 6	30 Sec	0~255 Sec	Default set time of soap 6.	End User
	9:Set time of soap 7	30 Sec	0~255 Sec	Default set time of soap 7.	End User
	10:Set time of soap 8	30 Sec	0~255 Sec	Default set time of soap 8.	End User
6: Inverter setup	1:Inverter type	Delta-EL	CMK、 LG-IG5,LG-IS5, Delta-EL	Brand of frequency converter.	Factory
	2:Inverter control mode	Relay	Relay、 Rs485	control mode.	Factory
	3:Base number of invert.	0	0~1	Base number of inverter while use input signal.	Factory
	4:Coefficient of frequency and speed	0.2400	0.0001~0.9999	Coefficient of frequency and rev : Frequency = Rev * Coefficient.	Factory
	5:Display actual rotation speed	No	No, Yes	Yes: On the Manual and Auto interface, display speed of Inverter.	Factory
	1:Minimum pause	5 Sec	1~255 Sec	Min time between forward and reverse to avoid motor overload.	Factory

7:Wash setup	forward/reversal				
	2:Standard wash run time	25 Sec	1~255 Sec	Standard wash run time, includes forward and reverse.	End User
	3:Standard wash stop time	5 Sec	1~255 Sec	Standard wash stop time, includes forward and reverse.	End User
	4:Gentle wash run time	5 Sec	1~255 Sec	Gentle wash run time, includes forward and reverse.	End User
	5:Gentle wash stop time	15 Sec	1~255 Sec	Gentle wash stop time, includes forward and reverse.	End User
	6:Heavy wash run time	60 Sec	1~255 Sec	Heavy wash run time, includes forward and reverse.	End User
	7:Heavy wash stop time	5 Sec	0~255 Sec	Heavy wash stop time, includes forward and reverse. When "Heavy wash stop time" is set to "0", it becomes single wash.	End User
	8: Speed of normal wash	40 rpm	1~ Max speed of wash	Default speed of wash.	End User
	9:Speed of gentle wash	40 rpm	1~ Max speed of wash	Default speed of wash.	End User
	10: Speed of single wash	40 rpm	1~ Max speed of wash	Default speed of wash.	End User
	11:Max speed of wash	60 rpm	40~100 rpm	Max speed of wash. Wash at max speed when the set value is larger than max speed.	Factory
8: Extract setup	1:High extract number	4	1~4	High extract number. There are four high extract most	Factory
	2:Level for balance	20cm	0~99cm	Auto fill to level at least before extract to avoid shock.	End User
	3:Balance drain level	15cm	0~99cm	If the level is higher than level at most after balance drain, controller will alarm.	End User
	4:Forward run time	10 Sec	1~255 Sec	Forward run time at beginning of extract.	End User

5:Balance with water time	30 Sec	1~255 Sec	Balance with water time at extract.	End User
6:Balance drain water time	60 Sec	1~255 Sec	Balance drain water time at extract.	End User
7:Mid extract time	60 Sec	1~255 Sec	Time of mid extract.	End User
8:High extract 1 time	60 Sec	1~255 Sec	Time of high extract 1.	End User
9:High extract 2 time	60 Sec	1~255 Sec	Time of high extract 2.	End User
10:High extract 3 time	60 Sec	1~255 Sec	Time of high extract 3.	End User
11:Maximum extract time	7 Min	1~255 Min	Max time of extract at last phase.	End User
12:Mid extract delay time	60 Sec	10~255 Sec	Delay time from end of mid extract.	Factory
13:High extract delay time	90 Sec	20~255 Sec	Delay time from end of high extract.	Factory
14:Re-extract times	3	0~20	Re-extract times when shock. If the times is larger than the set value, controller will alarm.	Factory
15:Re-extract wash time	60 Sec	0~255 Sec	Wash time before re-extract to unroll the clothes.	End User
16:Balance delay time	30 Sec	0~255 Sec	Delay time from end of balance.	End User
17:Forward run speed	40rpm	1~ Balance speed	Forward run speed at beginning of extract.	Factory
18:Balance speed	60rpm	Forward Speed~Mid extract speed	Balance speed at extract.	End User
19:Mid extract speed	300rpm	Balance Speed~MaxMid Extract Speed	Speed of mid extract.	End User
20:High extract 1 speed	500rpm	Mid Extract Speed~Hi2 Speed	Speed of high extract 1.	End User
21:High extract 2 speed	550rpm	Hi 1 Speed~Hi 3 Speed	Speed of high extract 2.	End User
22:High extract 3 speed	600rpm	Hi 2 Speed~Hi 4 Speed	Speed of high extract 3.	End User
23:High extract 4 speed	650rpm	Hi 3Speed~Max Hi ExtractSpeed	Speed of high extract 4.	End User

	24:Max speed of mid extract	400rpm	Mid extract speed ~600 rpm	Max speed of mid extract.	End User
	25:Max speed of hi extract	800rpm	High extract 1 speed ~999 rpm	Max speed of high extract.	Factory
9:Door lock setup	1:Unlock door temperature	40°C	0~90°C	Can't unlock the door when temperature is higher than safety temperature.	End User
	2:Unlock door level	5cm	0~99cm	Can't unlock the door when level is higher than safety level.	End User
	3:Door lock valve status	N.O.	N.C.,N.O.	Open: Door lock valve is opened while locked. Close: Door lock valve is closed while locked.	Factory
	4:Door lock type	Series	Series, Pulsed,Daul	Door lock type : Series and Pulsed,Dual.	Factory
	5:Unlock time in pulsed	10Sec	0~99 Sec	Unlock action time with pulsed.	Factory
	6:Max time of door pin	3 Sec	0~99 Sec	If lock or unlock time is longer than the max time, controller will alarm.	Factory
10:Coin setup	1:Pay type	Mode1	Mode1,Mode2, Free,Mode3		End User
	2:Pay unit type	Number	Number、Valuta、Need pay		Factory
	3:Coin Valuta	1.00	0.00-655.00		End User
	4:Max Coins	999	0-999	Set to 0 means not to alarm	End User
	5:P1 Need Coins	4	0-255	P1 program need coins	End User
	6:P2 Need Coins	4	0-255	P2 program need coins	End User
	7:P3 Need Coins	4	0-255	P3 program need coins	End User
	8:P4 Need Coins	4	0-255	P4 program need coins	End User
	9:P5 Need Coins	4	0-255	P5 program need coins	End User
	10:P6 Need Coins	4	0-255	P6 program need coins	End User
	11:Paid Then Run	NO	NO,YES	machine run after payment	
	12:Default Formula	1	1-3	Default formula number after entering the formula selection interface.	
	13:Enable discount?	NO	NO,YES	Enable discount.	
	14:Discount start time:	9	0~23	Discount start time.	

15:Discount end time:	11	0~23	Discount end time.	
16:P1 vend price after discount	2	1~255	P1 :Price to be paid after discount	
17:P2 vend price after discount	2	1~255	P2:Price to be paid after discount	
18:P3 vend price after discount	2	1~255	P3 :Price to be paid after discount	
19:P4 vend price after discount	2	1~255	P4 :Price to be paid after discount	
20:P5 vend price after discount	2	1~255	P5 :Price to be paid after discount	
21:P6 vend price after discount	2	1~255	P6 :Price to be paid after discount	

## 6.1 Discount

In the main menu interface, click < parameter setting >, then click < system setting >, and then click < other setting >.The discount function can only be used when the screen has batteries.

Discount time setting instructions:

A) Enable discount or not:Use or not discount function.

B) Actual time:Time now.Click time to set.

C) Week:If Monday is selected, Monday will be discounted; if Monday is not selected, there will be no discount on Monday,and so on.

1. Start time:Time to start discount.

2. End time:Time to end discount.

D) Limit dates: The discount is valid from the start date to the end date.The week setting is still in effect.

1. Start date:The date the discount begins.

2. End date:The date the discount ends.

Discount	
Enable discount or not	<input checked="" type="checkbox"/>
Time	>
Price after discount	>
Lucky cycle	50
Actual time	2024-04-11 10:18:31

### Discount price page options description:

Price of formula 1:The number of coins required for program 1 after discount.And so on.

Lucky user:After the machine runs for a certain number of times,users can use it once for free.

## 6.2 Parameter Initialization

In parameter setting page, press<system setting> to enter system setting page, press<parameter initialization> to initialize all of the parameters.

Note: Only manufacturer can initialize parameters. The parameters will be default after this operation.

### 6.2.1 Data transfer via USB drive

In parameter setting page, press<data transfer>to enter data transfer page.

Data transfer includes parameter and formula upload and download between controller and USB drive.



Data transfer includes 4 different functions as below:

- 1、 Transfer parameters from USB drive to controller;
- 2、 Transfer formulas from USB drive to controller;
- 3、 Transfer parameters from controller to USB drive;
- 4、 Transfer formulas from controller to USB drive.

## 6.3 Update software via USB drive

In parameter setting page, press<software updation> to enter software updation page. In this page, user can update software of control board LY014A and operation panel HM166A.

While updating the software, the rate of progress will be displayed as percent. Do not pull out the USB drive until 100% displayed.

**Note: Insert the USB drive first,then enter the updation page;**

**The file of software should be a subdirectory of the root directory.**

## 6.4 USB functions alarms

The alarms below may occur when user update the software via USB drive.Please resolve the problems according to the methods and information as below.

NO.	Error name	Reset		Reasons	Trouble shooting
		MANU ALLY	Auto		
#1	USB not found	√		USB drive not detected	<ol style="list-style-type: none"> <li>1. Check if the USB drive inserted firmly;</li> <li>2. Change a USB drive to try again.</li> </ol>
#2	File not found	√		File path or name not right	<ol style="list-style-type: none"> <li>1. Check if the file name is right ;</li> <li>2. Check if the file is in the right file directory.</li> </ol>

#3	USB status error	✓		USB system error	1. Contact with supplier
#4	Unkown error	✓		USB system error	1. Contact with supplier
#5	File datas wrong	✓		Datas are nor right	1. Copy a new file to the required file path to have a try



**Please contact with your machine supplier for further help if the alarms can not be eliminated by yourself.**

## 7. Alarm

### 7.1. Alarm Reset

KH18070HSA 6411 When error occurs, the computer will signal an alarm automatically with audible sound. Pressing <Enter>button will stop audible alarm sound. Press <Enter>button again after troubleshooting. If the error has been resolved or can be ignored, the computer will go back to “open” or “close” or “locked” status. Or else the computer will alarm again.

### 7.1.1. Alarm Information and Obviation

No.	Alarm Name	Troubleshooting
#1	Error door status	Please check the door switch or door pin.
#3	Over shock	Please check the capacity of machine, or the clothes knot, or check the input of over shock.
#5	Emergency stop	Pressed the emergency button, please check and release it. Or check the input of emergency stop.
#7	Inverter error	Please check the inverter, or check the input of inverter
#9	Error level sensor	Have not adjusted the level sensor, please contact with factory.
#10	Temp sensor of water	Please check temperature sensor of water, or try another one.
#11	Temp sensor of dry	Please check temperature sensor of inverter, or try another one.
#14	Overtime of fill	Can't reach the set level in time. Please check the fill valve, or check the level sensor.
#15	Overtime of heat	Can't reach the set temperature in time. Please check the device of heat, or check the temperature sensor.
#16	Overtime of drain	There are also some water in basket when drain of extract. Please check the drain valve.
#17	Lubrication time	The times of run can be browsed and be cleared as following operation:  While time count down after power on , pressing[STOP] and P4 at the same time to enter statistic page, press set button for 3 seconds to clear this alarm.
#18	Invt comm overtime	Can't receive replay data from inverter. Please check power of inverter, or the parameter of the inverter.
#19	Inverter comm intfer	Please check whether strong or weak electricity insulate or not or machine whether to connect the earth or not.
#20	Inverter error	Refer to the table of inverter faults.
#21	High temp of invt	Clear cila of inverter and check the fan of inverter.
#33	Inverter alarm	Refer to the table of Inverter alarms.
#34	Clear cilia of invt	Clear cila of Inverter and check the fan of Inverter.
#49	Bkbd comm overtime	Can't receive replay data from I/O Board. Please check the wiring between HMI and I/O Board.
#50	Bkbd comm intfer	Please check whether strong or weak electricity insulate or not or machine whether to connect the earth or not.
#51	Parameter error	Please contact with factory.
#52	Program error	Please contact with factory.
#53	Controller failure	Please contact with factory.

# Tumble Dryers

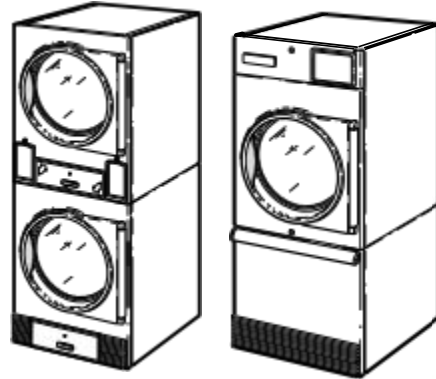

TMB1281C\_SVG

## **Original Instructions**

**Keep These Instructions for Future Reference.**

**CAUTION: Read the instructions before using the machine.**

(If this machine changes ownership, this manual must accompany machine.)

Installation/Maintenance/Operation

Installation must conform with local codes or, in the absence of local codes, with:

In the U.S.A., installation must conform to the latest edition of the American National Standard Z223.1/ NFPA 54 “National Fuel Gas Code” and Standard ANSI/NFPA 70 “National Electric Code.”

In Canada, installation must comply with Standards CAN/CSA-B149.1 Natural Gas and Propane Installation Code and CSA C22.1, latest edition, Canadian Electric Code, Part I.

In Australia and New Zealand, installation must comply with the Gas Installations Standard AS/NZS 5601 Part 1: General Installations.

In Europe, before installation, check that the local distribution conditions, nature of gas and pressure, and the adjustment of the appliance are compatible.

This equipment has been designed and certified to comply with IEC/EN 60335 electrical safety standards for tumble dryers.



Read all instructions before using tumble dryer.

**IMPORTANT: If it is unavoidable that fabrics that contain vegetable or cooking oil or have been contaminated by hair care products be placed in a tumble dryer, they should first be washed in hot water with extra detergent. This will reduce, but not eliminate, the hazard.**

	<b>WARNING</b>
<b>FOR YOUR SAFETY, the information in this manual must be followed to minimize the risk of fire or explosion or to prevent property damage, personal injury or death.</b>	
W033	

	<b>DANGER</b>
<b>Electric shock hazard will result in death or serious injury. Disconnect all electric power to appliance and accessories and wait five (5) minutes before servicing.</b>	
W925	

Units are IPx4 when enclosed per these instructions.

	<b>WARNING</b>
<ul style="list-style-type: none"><li>• <b>Do not store or use gasoline or other flammable vapors and liquids in the vicinity of this or any other appliance.</b></li><li>• <b>WHAT TO DO IF YOU SMELL GAS:</b><ul style="list-style-type: none"><li>• <b>Do not try to light any appliance.</b></li><li>• <b>Do not touch any electrical switch; do not use any phone in your building.</b></li><li>• <b>Clear the room, building or area of all occupants.</b></li><li>• <b>Immediately call your gas supplier from a neighbor's phone. Follow the gas supplier's instructions.</b></li><li>• <b>If you cannot reach your gas supplier, call the fire department.</b></li></ul></li><li>• <b>Installation and service must be performed by a qualified installer, service agency or the gas supplier.</b></li></ul>	
W052	

**IMPORTANT: Information must be obtained from a local gas supplier on instructions to be followed if the user smells gas. These instructions must be posted in a prominent location. Step-by-step instructions of the above safety information must be posted in a prominent location near the tumble dryer for customer use. IMPORTANT: Post the following statement in a prominent location**

**FOR YOUR SAFETY**

**Do not store or use gasoline or other flammable vapors and liquids in the vicinity of this or any other appliance.**

**IMPORTANT: The installer must fully test the tumble dryer after installation and demonstrate to the owner how to operate the machine.**

**IMPORTANT: The machine shall only be installed in a room separated from inhabited rooms, incorporating appropriate ventilation specified in the National Installation Regulations.**

**IMPORTANT: The tumble dryer is not to be used if industrial chemicals have been used for cleaning.**

	<b>WARNING</b>
<p>To reduce the risk of electric shock, fire, explosion, serious injury or death:</p> <ul style="list-style-type: none"> <li>• Disconnect electric power to the tumble dryer before servicing.</li> <li>• Close gas shut-off valve to gas tumble dryer before servicing.</li> <li>• Close steam valve to steam tumble dryer before servicing.</li> <li>• Never start the tumble dryer with any guards/panels removed.</li> <li>• Whenever ground wires are removed during servicing, these ground wires must be reconnected to ensure that the tumble dryer is properly grounded.</li> </ul>	
W002R1	

	<b>WARNING</b>
<ul style="list-style-type: none"> <li>• Installation of unit must be performed by a qualified installer.</li> <li>• Install tumble dryer according to manufacturer's instructions and local codes.</li> <li>• DO NOT install a tumble dryer with flexible plastic venting materials. If flexible metal (foil type) duct is installed, it must be of a specific type identified by the appliance manufacturer as suitable for use with tumble dryer. Refer to section on connecting exhaust system. Flexible venting materials are known to collapse, be easily crushed, and trap lint. These conditions will obstruct tumble dryer airflow and increase the risk of fire.</li> </ul>	
W752R1	

	<b>CAUTION</b>
<p><b>TO AVOID THE RISK OF FIRE THIS DRYER MUST BE EXHAUSTED OUTDOORS.</b></p>	
W928	

	<b>WARNING</b>
--	----------------

	<b>WARNING</b>
<p>Electrical shock hazard can cause death or serious injury. To reduce the risk of electric shock, disconnect all electric power to appliance and accessories before servicing.</p>	
W929	

	<b>WARNING</b>
<p>Moving parts hazard can cause serious injury. Disconnect electric power to unit before servicing. Unexpected start of machinery will occur if the unit is equipped with the extended tumble feature.</p>	
W937	

	<b>WARNING</b>
<p>Lint compartment must be cleaned daily To avoid the risk of fire:</p> <ul style="list-style-type: none"> <li>• Use for drying water washed fabrics only.</li> <li>• DO NOT dry articles containing foam rubber, plastic, or similarly textured rubber like materials.</li> <li>• DO NOT put articles soiled with cooking oil in dryer as cooking oil may not be removed during washing. Due to the remaining oil the fabric may catch on fire by itself.</li> <li>• DO NOT put articles soiled with flammable liquids or flammable cleaning solvents in dryer.</li> </ul>	
W930	

	<b>CAUTION</b>
<ul style="list-style-type: none"> <li>• Risk of fire, a clothes dryer produces combustible lint. Exhaust outdoors. Care should be taken to prevent the accumulation of lint around the exhaust opening and in the surrounding area.</li> <li>• DO NOT reach into the dryer until all moving parts have stopped.</li> <li>• DO NOT let children play on or in the dryer.</li> </ul>	
W931	

In Australia and New Zealand:

**To reduce the risk of serious injury: Avoid contact with hot surfaces.**

W927



## WARNING

- **DO NOT** operate this appliance before reading the instruction booklet.
- **DO NOT** place articles on or against this appliance.
- **DO NOT** store chemicals or flammable materials or spray aerosols near this appliance.
- **DO NOT** operate with panels, covers or guards removed from this appliance.
- **DO NOT** load materials containing flammable solvents into this appliance.
- **If repeated ignition reset is required, the dryer should not be used and a service call booked.**



**Risk of fire/flammable material.**

W926

The following information applies to the state of Massachusetts, USA.

- This appliance can only be installed by a Massachusetts licensed plumber or gas fitter.
- This appliance must be installed with a 36 inch [91 cm] long flexible gas connector.
- A “T-Handle” type gas shut-off valve must be installed in the gas supply line to this appliance.
- This appliance must not be installed in a bedroom or bathroom.

# Table of Contents

<b>Safety Information.....</b>	
Important Safety Instructions.....	
Explanation of Safety Messages.....	
<b>Specifications and Dimensions.....</b>	
Specifications and Dimensions.....	
Cabinet Dimensions – 025, 030, 035 and 055 Series.....	
Cabinet Dimensions – BT30 and BT50 Series.....	
Exhaust Outlet Locations – 025, 030, 035 and 055 Series.....	
Exhaust Outlet Locations – BT30 and BT50 Series.....	
Gas Connection Locations – 025, 030, 035 and 055 Series.....	
Gas Connection Locations – BT30 and BT50 Series.....	
Electrical Connection Locations – 025, 030, 035 and 055 Series.....	
Electrical Connection Locations – BT30 and BT50 Series.....	
<b>Installation.....</b>	
Pre-Installation Inspection.....	
Location Requirements.....	
Position and Level the Tumble Dryer.....	
Fifth Leveling Leg.....	
Before Placing Tumble Dryer into Service.....	
<b>Exhaust Requirements.....</b>	
Exhaust Requirements.....	
Layout.....	
Make-Up Air.....	
Venting.....	
Individual Venting.....	

Manifold Venting.....

**Gas Requirements.....**

Gas Requirements.....

How to Change Burner Orifice Size.....

How to Adjust Gas Valve Governor/Regulator.....

Start-Up Procedure.....

**Electrical Requirements.....**

Electrical Requirements.....

Wiring Diagram.....

**Adjustments.....**

Adjustments.....

Gas Burner Air Shutter.....

Airflow Switch .....

Loading Door Switch.....

Door Strike.....

Manual Resettable Thermostat.....

**Removing Tumble Dryer from Service.....**

**Maintenance .....**

# Specifications and Dimensions

## Specifications and Dimensions

		BT035	BT055
ControlOption		Touch/Keypad	Touch/Keypad
Capacity-Ib (kg)		35 (16)	55 (24)
Overall Width-in (mm)		31.5 (800)	34.5 (875)
Overall Depth-in (mm)		45.5 (1157)	53.0 (1346)
Overall Height-in (mm)		64.0 (1625)	66.9 (1700)
Cylinder Diameter-in (mm)		30 (762)	33 (838)
Cylinder Depth-in (mm)		30 (762)	35.0 (889)
Cylinder Volume- cu. ft (liters)		12.3 (350)	17.3 (490)
Reversing Cylinder		Standard	Standard
Door Opening Size -in (mm)		22.7 (576)	26.9 (683)
Heat Input Power - Btu/hr (kw)	Full type  Save type	90,000 (24) 61,424 (18)	112,000 (27) 61.424 (18)
Gas Connections*-in (npt)		0.5 (npt)	0.5 (npt)
Air Outlet -in (mm)		8 (200)	8 (200)
Motor -HP (kw)	Fan	0.5 (0.4)	0.5 (0.4)
	Cylinder	0.3 (0.2)	0.5 (0.4)
Airflow-cfm		600 (280)	700 (330)
Shipping Dimensions Approx. -in (mm)	Width	33 (840)	35.5 (900)
	Depth	49 (1240)	57 (1450)
	Height	67.6 (1720)	70.5 (1790)
Net Weight-Ib (kg)		340 (155)	438 (199)
Shipping Weight-Ib (kg)		360 (165)	478 (212)

## Specifications and Dimensions

		BTBT30	BTT50
Control Option		Touch/Keypad	Touch/Keypad
Capacity-Ib (kg)		2X30 (13)	2X50 (23)
Overall Width-in (mm)		31.5 (800)	34.4 (875)
Overall Depth-in (mm)		43.9 (1116)	49.8 (1266)
Overall Height-in (mm)		76.0 (1932)	81.1 (2061)
Cylinder Diameter-in (mm)		30.0 (762)	33.0 (838)
Cylinder Depth-in (mm)		26.0 (660)	30.0 (762)
Cylinder Volume-cu. ft (liters)		10.6 (300)	14.8 (420)
Reversing Cylinder		Standard	Standard
Door Opening Size -in (mm)		22.6 (574)	26.9 (683)
Heat Input Power -Btu/hr (kw)	Full type	2X73,000 (21.4)	2X95,000 (27)
	Save type	2X40,949 (12)	
Gas Connections*in (npt)		0.5 (npt)	0.5 (npt)
Air Outlet -in (mm)	Standard	1X8 (200) oval	1x10 (250) oval
Motor -HP (kw)	Fan	2X0.5 (0.4)	2X0.5 (0.4)
	Cylinder	2X0.5 (0.4)	2X0.5 (0.4)
Airflow-cfm		2X400 (380)	2x600 (285)
Shipping Dimensions Approx-in (mm)	Width	32.5 (830)	35.5 (900)
	Depth	47.0 (1190)	54.0 (1370)
	Height	79.9 (2030)	84.9 (2160)
Net Weight-Ib (kg)	Standard	580 (265)	690 (315)
Shipping Weight -Ib (kg)	Standard	615 (280)	735 (335)

## Cabinet Dimensions – 035 and 055 Series

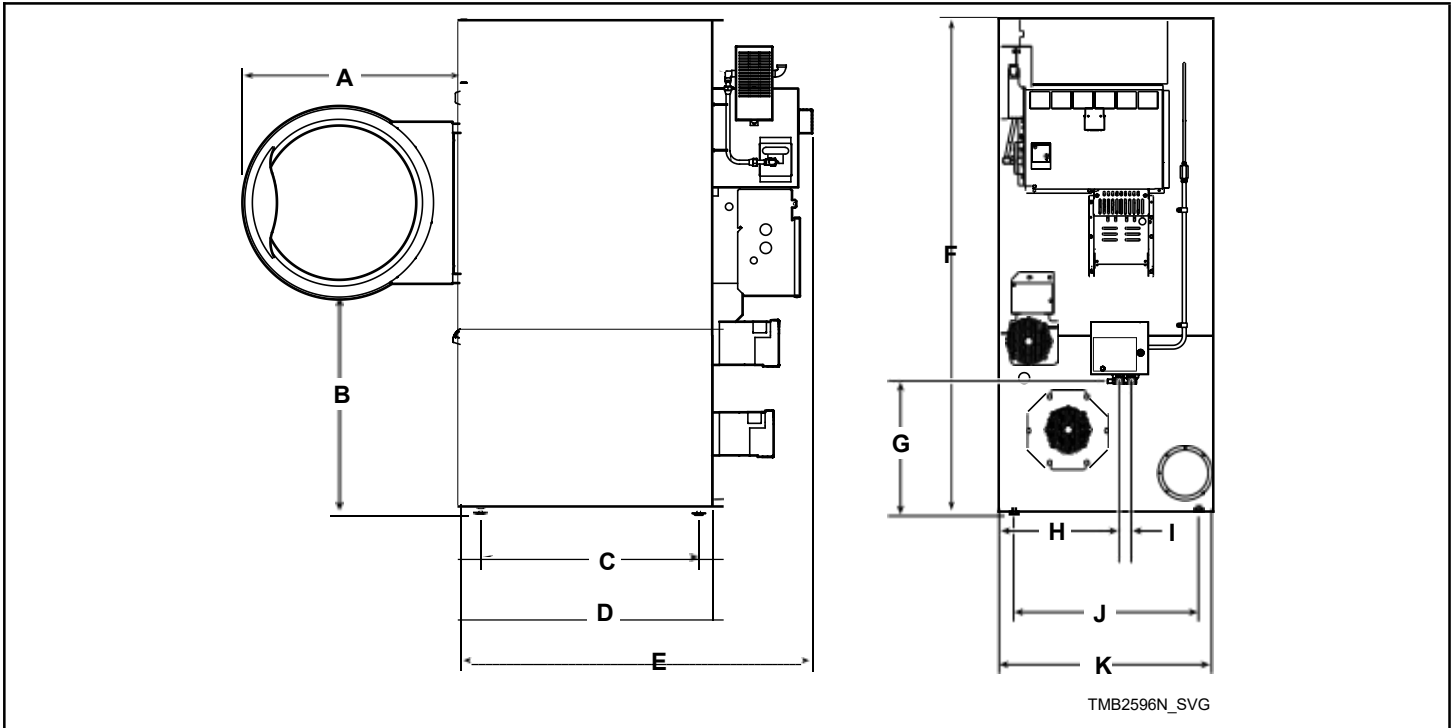

Table 3 *continues...*

Machine Dimensions, in. [mm]					
Models	A	B	C	D	E
035 Series	28.0 [710]	27.5 [700]	28.4 [720]	31.8 [810]	45.5 [1,155]
055 Series	31.9 [810]	26.9 [680]	33.4 [850]	36.8 [935]	53.1 [1,350]

Table 3

Models	F	G*	H*	I*	J	K
035 Series	63.9 [1,625]	16.5 [420]	19.6 [500]	1.6 [40]	27.4 [695]	31.5 [800]
055 Series	66.7 [1,700]	17.75 [450]	18.7 [475]	1.6 [40]	30.5 [775]	34.5 [875]

\* Fire suppression system optional - may not be on machine.

**NOTE: Facia panels available to increase height of models to 72.25 inches [1,840 mm] and 76.25 inches [1,940 mm].**

## Cabinet Dimensions – BT30 and BT50 Series

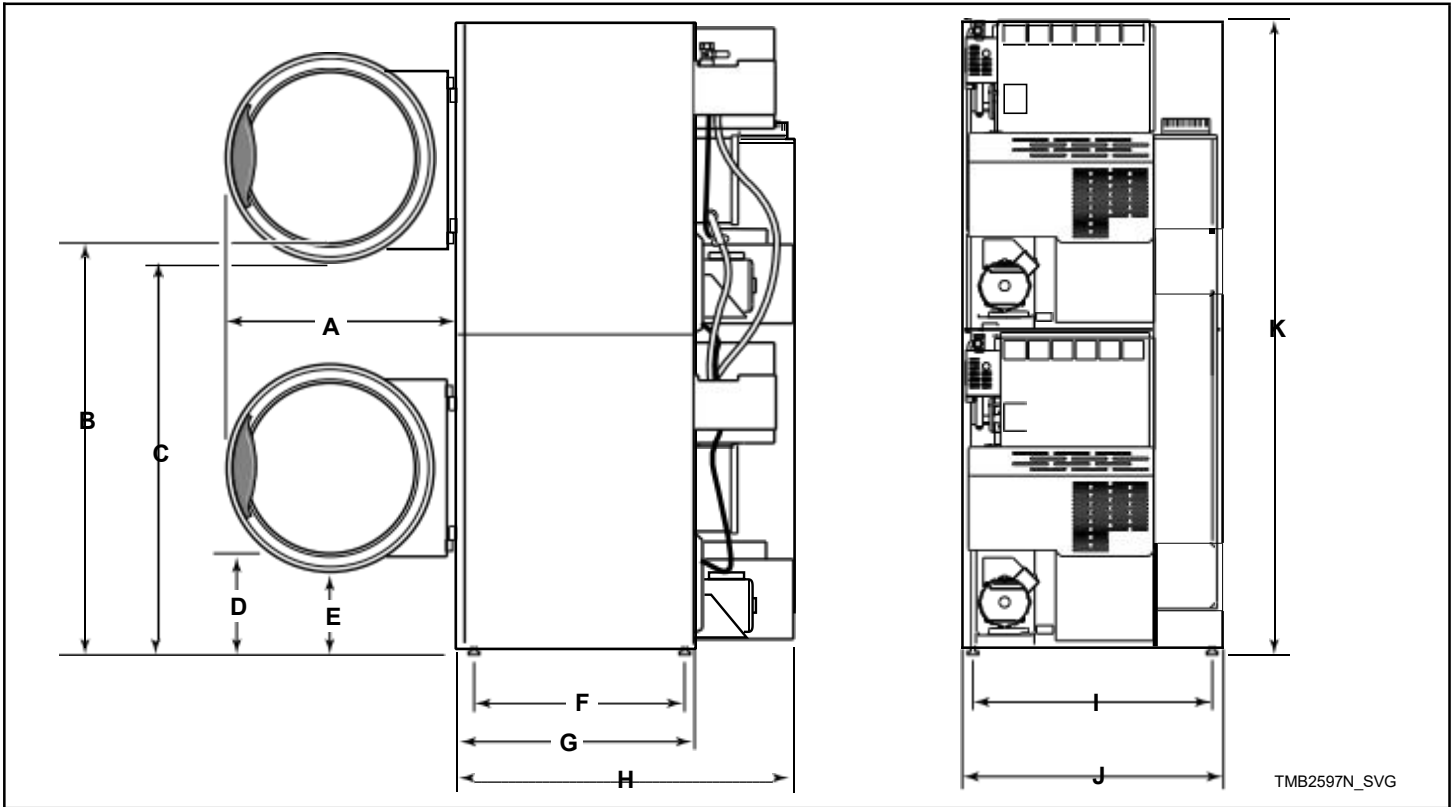

Machine Dimensions, in. [mm]					
Models	A	B	C	D	E
BT30 Series	28.0 [710]	49.0 [1,245]	48.3 [1,225]	11.4 [290]	10.7 [270]
BT50 Series	31.9 [810]	50.4 [1,280]	49.3 [1,250]	10.3 [260]	9.3 [235]

Table 4

Models	F	G	H	I	J	K
BT30 Series	25.0 [635]	28.7 [730]	42.8 [1,090]	27.4 [695]	31.5 [800]	76.3 [1,940]
BT50 Series	29.0 [735]	32.7 [830]	48.6 [1,235]	30.4 [770]	34.5 [875]	81.3 [2,065]

**NOTE: To meet Americans with Disabilities Act (ADA) compliance, install a 4 inch [100 mm] riser on BT30 models only.**

## Exhaust Outlet Locations – 035 and 055 Series

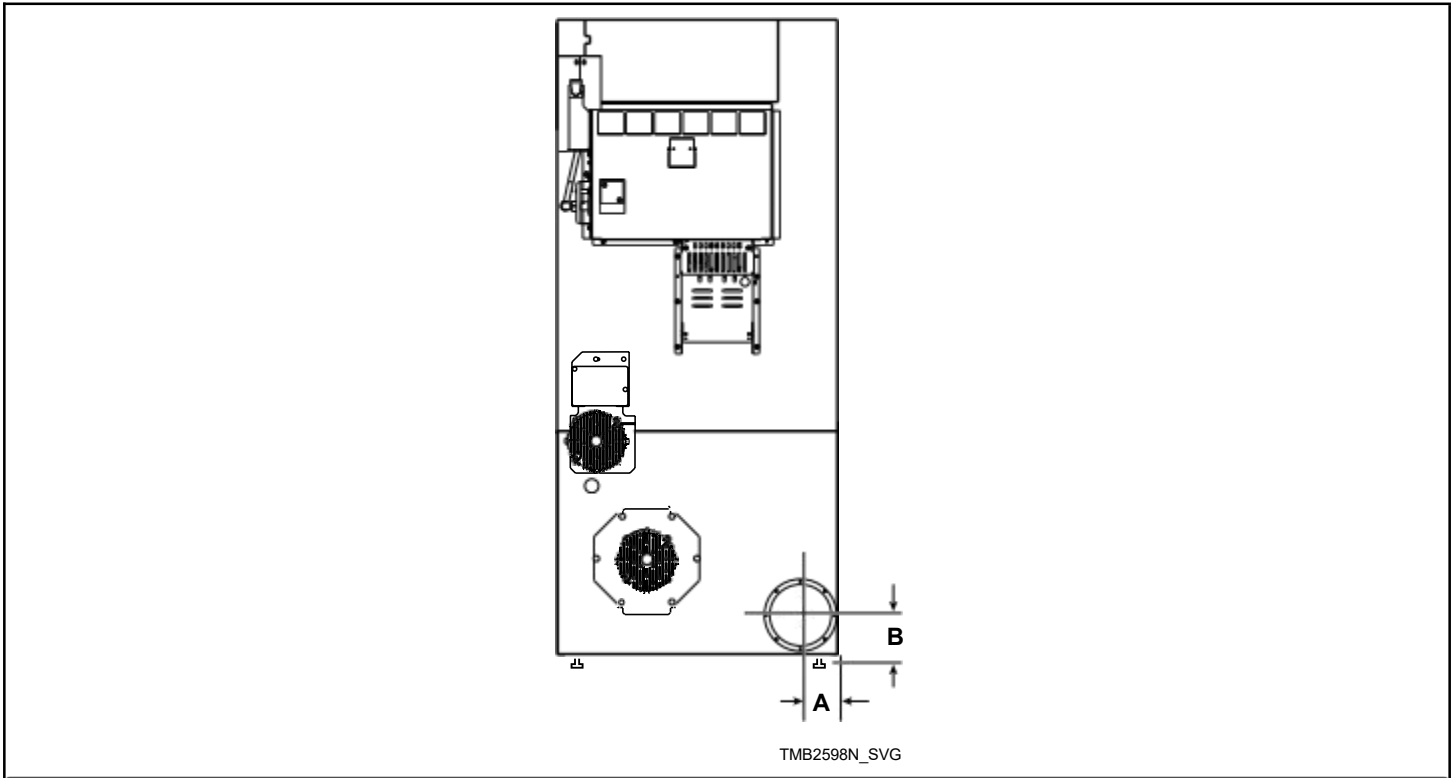

Models	Rear Exhaust Dimensions, in. [mm]			
	Diameter		A	B
030 Series	Standard Line 6.0 [150]	Eco Line 6.0 [150]	3.9 [100]	4.6 [115]
035 Series	Standard Line 8.0 [200]	Eco Line 6.0 [150]	4.9 [125]	5.6 [145]
055 Series	Standard Line 8.0 [200]	Eco Line 8.0 [200]	4.9 [125]	5.6 [145]

Table 5

## Exhaust Outlet Locations – BT30 and BT50 Series

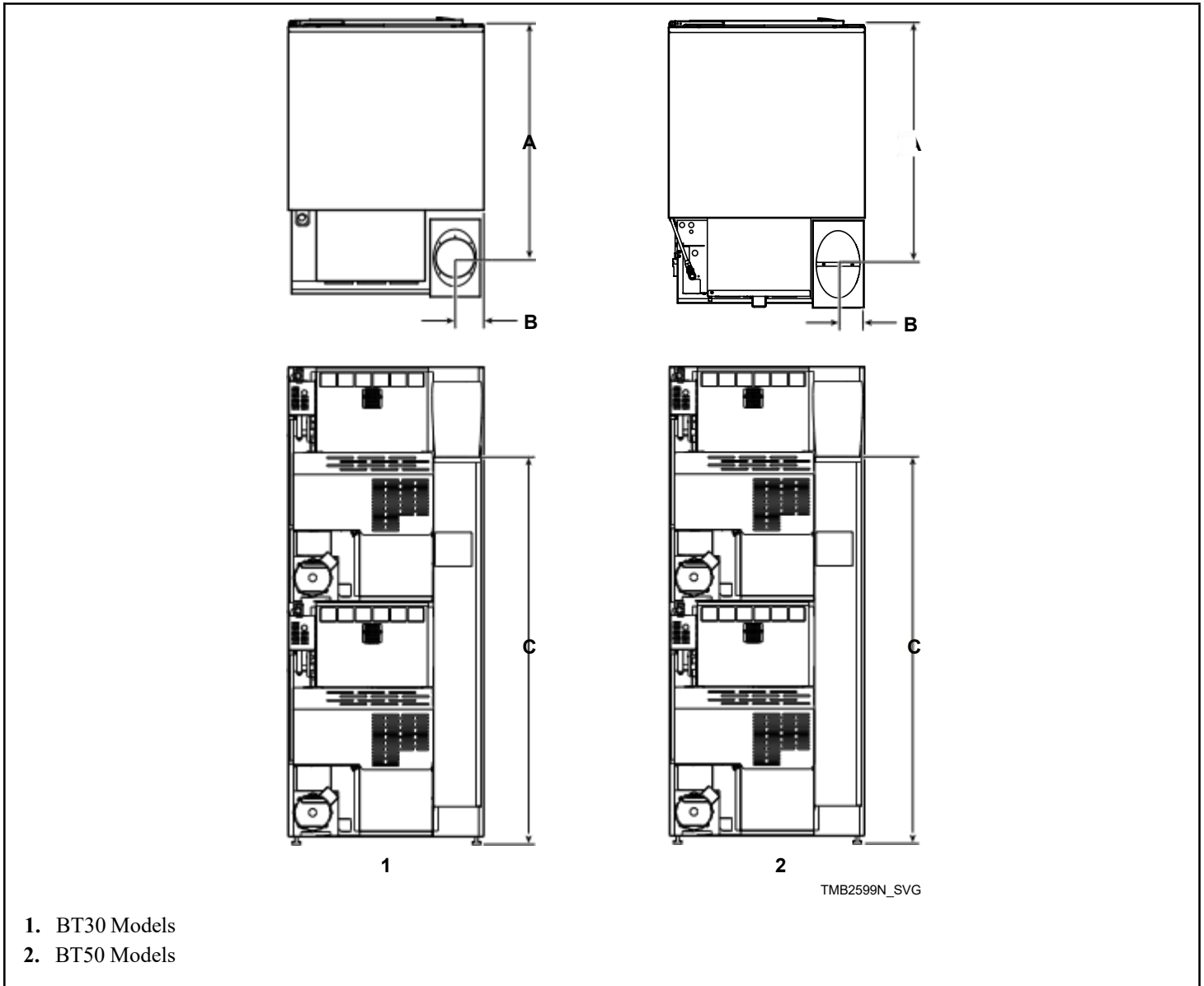

Models	Rear Exhaust Dimensions, in. [mm]				
	Diameter		A	B	C
BT30 Series	Standard Line Elliptical Fits 8.0 [200]	Eco Line Round Fits 6.0 [150]	36.5 [930]	4.3 [110]	62.4 [1,585]

Table 6 continues...

Models	Rear Exhaust Dimensions, in. [mm]				
	Diameter		A	B	C
BT50 Series	Standard Line Elliptical Fits 10.0 [250]	Eco Line Elliptical Fits 10.0 [250]	40.9 [1,040]	4.8 [120]	66.0 [1,675]

Table 6

## Gas Connection Locations – 035 and 055 Series

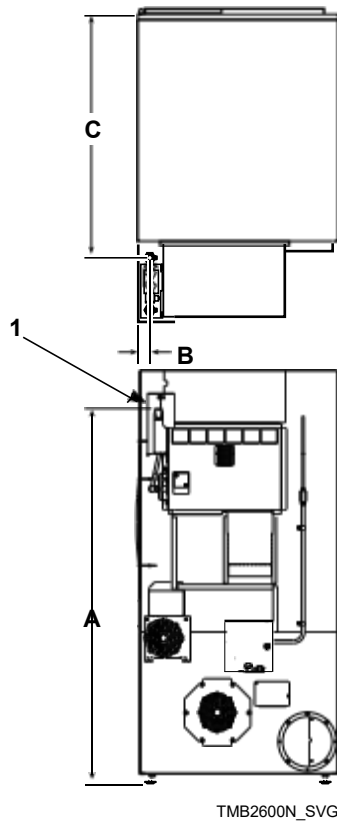

1. 1/2 NPT

Models	Gas Connection, in. [mm]		
	A	B	C
035 Series	58.0 [1,475]*	3.0 [75]	41.5 [1,055]
055 Series	55.0 [1,400]	1.6 [40]	49.0 [1,245]*
* IEC models add 0.5 [12]			

Table 7

## Gas Connection Locations – BT30 and BT50 Series

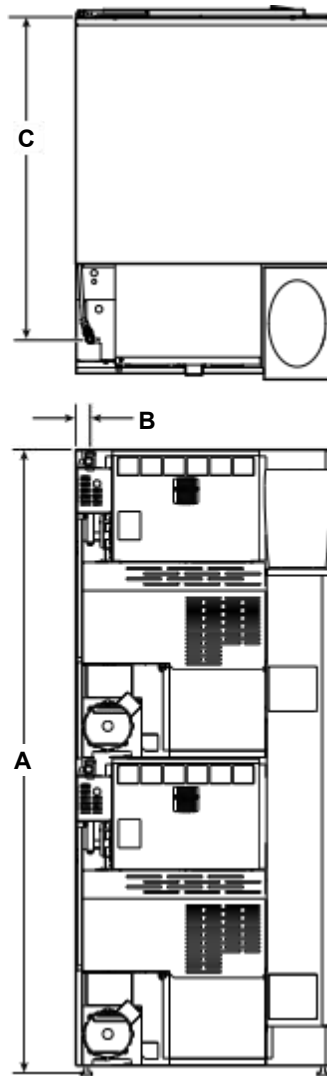

TMB2656N\_SVG

1. 1/2 NPT

Models	Gas Connection, in. [mm]		
	A	B	C
BT30 Series	75.5 [1,920]	1.7 [45]	36.8 [935]
BT50 Series	79.0 [2,005]	4.1 [105]	42.9 [1,090]

Table 8

# Electrical Connection Locations – 030, 035 and 055 Series

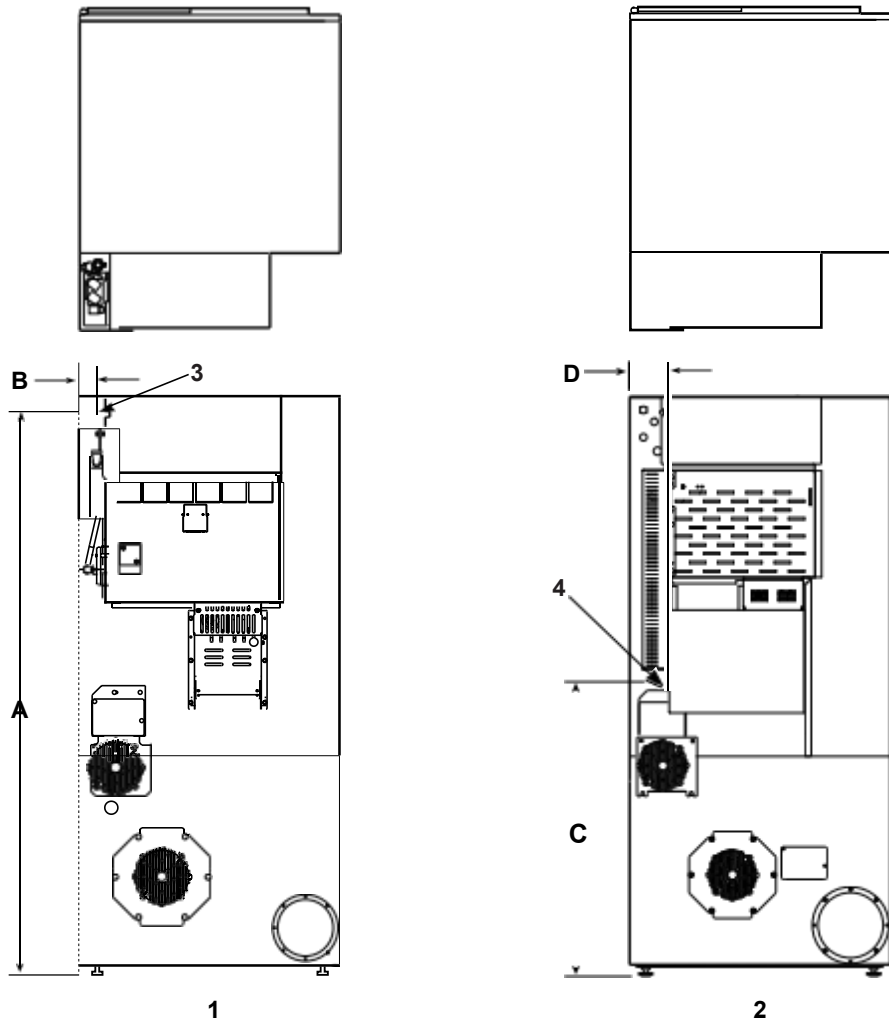

TMB2685N\_SVG

- 1. Gas and Steam
- 2. Electric
- 3. Electrical Connection 0.875 in. [22 mm] Diameter
- 4. Electrical Connection 1.375 in. [35 mm] Diameter

Models	Electrical Service Dimensions, in. [mm]			
	Gas and Steam Models		Electric Models	
	A	B	C	D
035 Series	62.3 [1,580]	1.8 [45]	29.6 [750]	5.0 [130]

Table 9 continues...

Models	Electrical Service Dimensions, in. [mm]			
	Gas and Steam Models		Electric Models	
	A	B	C	D
055 Series	64.6 [1,640]	1.8 [45]	30.5 [775]	6.6 [170]

Table 9

## Electrical Connection Locations – BT30 and BT50 Series

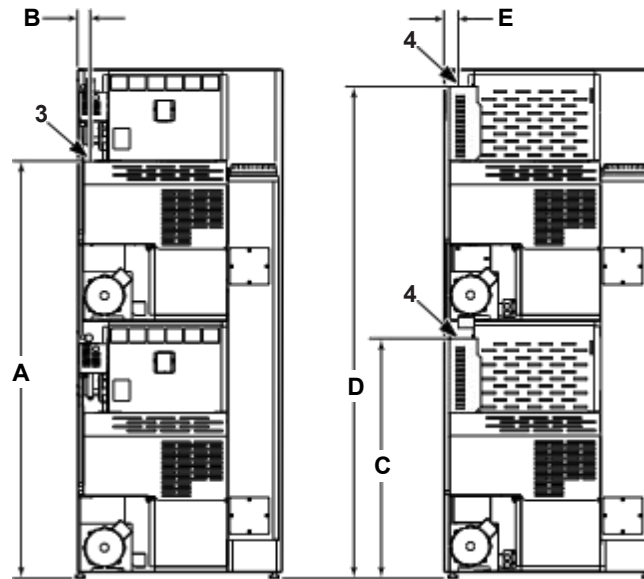

1

2

TMB2603N\_SVG

1. Gas and Steam
2. Electric
3. Electrical Connection 0.875 in. [22 mm] Diameter
4. Electrical Connection 1.625 in. [40 mm] Diameter

Models	Electric Service Dimensions, in. [mm]				
	Gas and Steam Models		Electric Models		
	A	B	C	D	E
BT30 Series	62.0 [1,575]	1.5 [40]	35.7 [905]	73.2 [1,860]	2.3 [60]
BT50 Series	65.6 [1,665]	2.3 [60]	Not Applicable	Not Applicable	Not Applicable

Table 10

## Steam Connection Locations – 035 Series

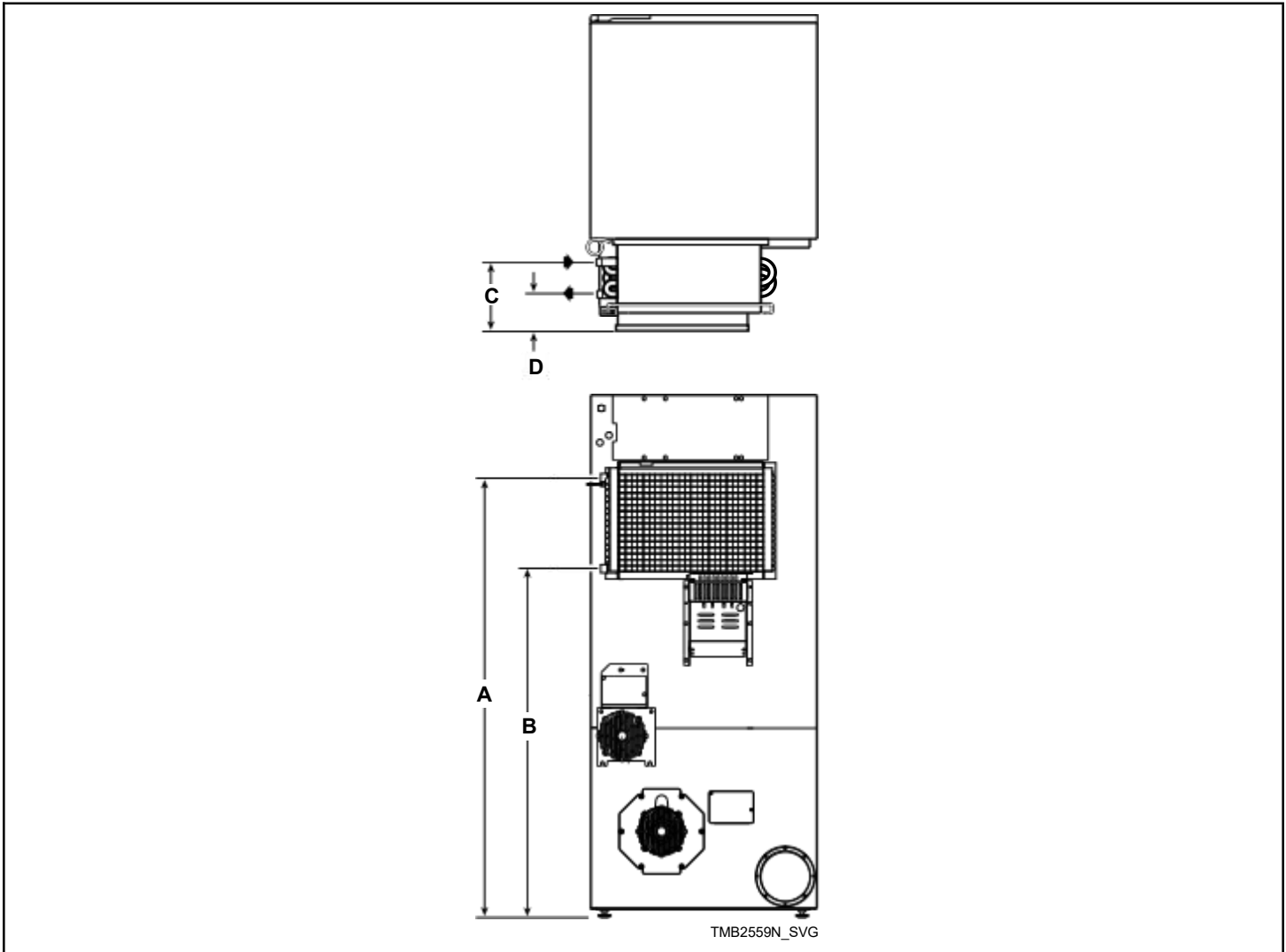

Models	Inlet Dimensions, in. [mm]		Outlet Dimensions, in. [mm]	
	A	C	B	D
035 Series	53.6 [1,360]	5.3 [135]	42.3 [1,075]	1.4 [35]

Table 11

**NOTE: All connections use 3/4 NPT pipe.**

## Steam Connection Locations – BT30 Series

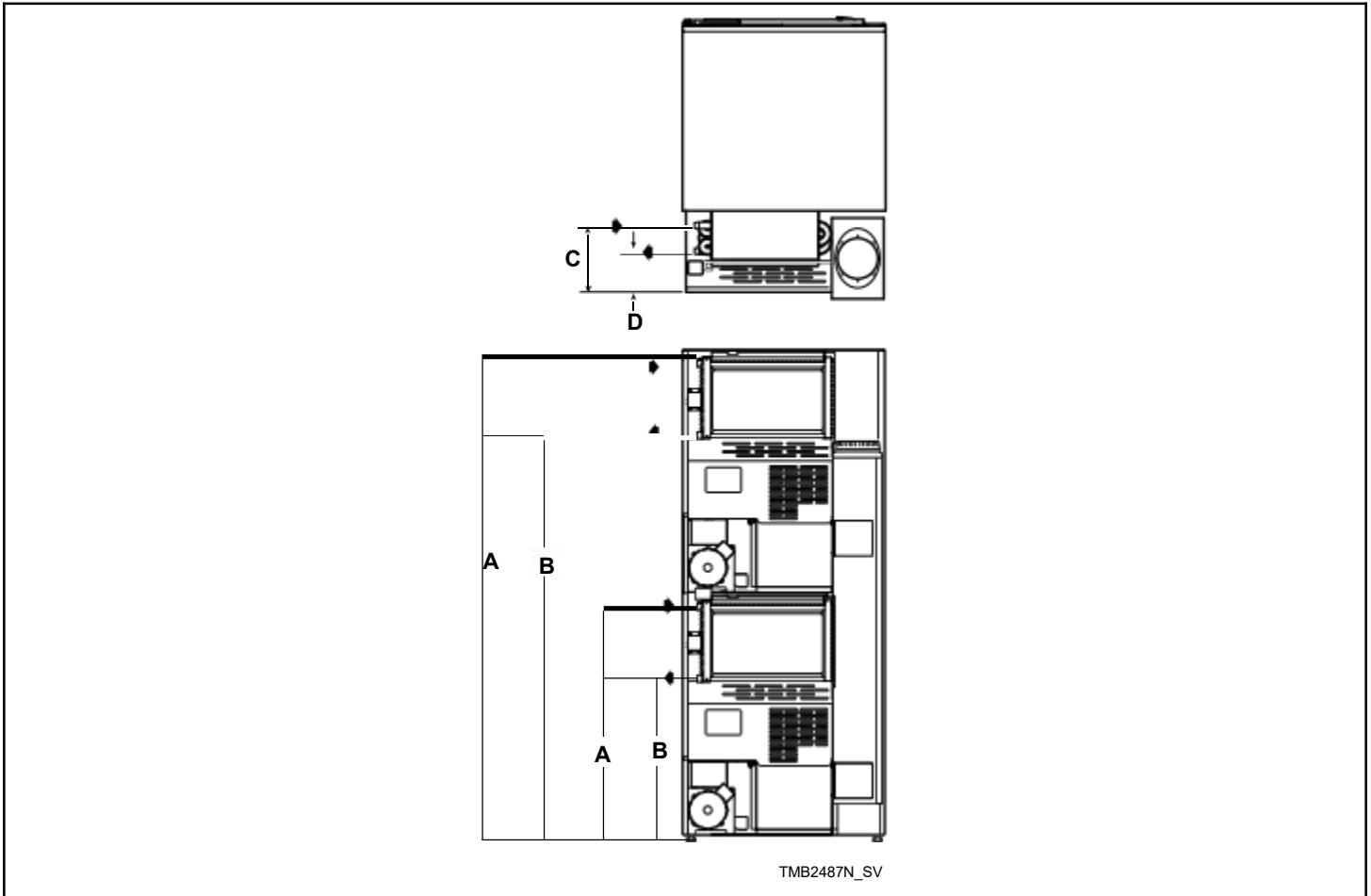

Models	Inlet Dimensions, in. [mm]		Outlet Dimensions, in. [mm]	
	A	C	B	D
BT30 Series (Upper)	74.0 [1,880]	6.3 [160]	62.8 [1,595]	2.4 [60]
BT30 Series (Lower)	36.4 [925]	10.1 [255]	25.5 [650]	6.2 [160]

Table 12

**NOTE: All connections use 3/4 NPT pipe.**

# Installation

## Pre-Installation Inspection

Upon delivery, visually inspect the crate, carton and parts for any visible shipping damage. If the crate, carton, or cover is damaged or signs of possible damage are evident, have the carrier note the condition on the shipping papers before the shipping receipt is signed, or advise the carrier of the condition as soon as it is discovered.

Remove the crate and protective cover as soon as possible and check the items listed on the packing list. Advise the carrier of any damaged or missing articles as soon as possible. A written claim should be filed with the carrier immediately if articles are damaged or missing.

**IMPORTANT: Remove the yellow shipping wire tie securing the airflow switch.**

**IMPORTANT: Warranty is void unless tumble dryer is installed according to instructions in this manual. Installation should comply with minimum specifications and requirements detailed in this manual and applicable local gas fitting regulations, municipal building codes, water supply regulations, electrical wiring regulations, and any other relevant statutory regulations. Due to varied requirements, applicable local codes should be thoroughly understood and all pre-installation work arranged for accordingly.**

Materials Required (Obtain Locally)	
All Models	Fused disconnect switch or circuit breaker on 1 Phase models. Circuit breaker on 3 Phase models.
Gas Models	One gas shut-off valve for gas service line to each tumble dryer.

*Table continues..*

Materials Required (Obtain Locally)	
Steam Models	One steam shut-off valve for steam service line to be connected upstream of solenoid steam valve. Two steam shut-off valves for each condensate return line. Flexible steam hoses with a 125 psig [pounds per square inch gauge] [862 kPa] working pressure for connecting steam coils. Refer to <i>Figure 24</i> for sizing and connection configurations. Two steam traps for steam coil outlets to condensate return line. Optional – Two vacuum breakers for condensate return lines.

**IMPORTANT: 3 Phase Only – Each tumble dryer must be connected to its own individual branch circuit breaker, not fuses, to avoid the possibility of “single phasing” and causing premature failure of the motor(s).**

## Location Requirements

The tumble dryer must be installed on a level floor. Floor covering materials such as carpeting or tile should be removed.

To assure compliance, consult local building code requirements. The tumble dryer must not be installed or stored in area where it will be exposed to water and/or weather.

**IMPORTANT: DO NOT block the airflow at the rear of the tumble dryer with laundry or other articles. Doing so would prevent adequate air supply to the combustion chamber of the tumble dryer.**

A typical tumble dryer enclosure is shown in *Figure 2*.

**IMPORTANT: Install tumble dryers with sufficient clearance for servicing and operation, refer to *Figure 2*.**

**IMPORTANT: The dryer must not be installed behind a lockable door, a sliding door or a door with a hinge on the opposite side to that of the tumble dryer, in such a way that a full opening of the tumble dryer door is restricted.**



## WARNING

To reduce the risk of severe injury, clearance of tumble dryer cabinet from combustible construction must conform to the minimum clearances, and/or local codes and ordinances.

W770R1

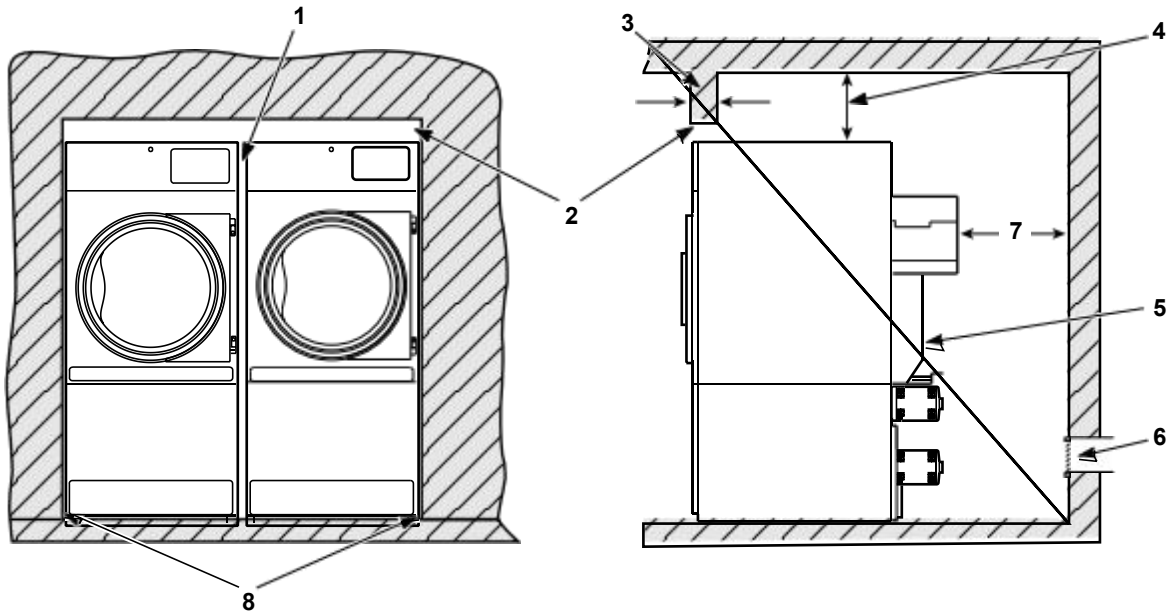

TMB2497N\_SVG

**NOTE: Shaded areas indicate adjacent structure.**

1. 0.0 in. [0 mm] minimum, 0.5 in. [13 mm] recommended between machines for removal or installation
2. Allow 2-4 in. [51-100 mm] opening at top of machine to aid in removal or installation. A removable trim piece may be used to conceal the opening; zero clearance allowed for trim.
3. 4 in. [100 mm] maximum header thickness
4. Minimum clearance permitted for remainder: 12 in. [300 mm]
5. Guard
6. Provision for make-up air
7. 24 in. [610 mm] minimum, 36 in. [910 mm] recommended for maintenance purposes
8. 0.0 in. [0 mm] minimum, 0.25 in. [6 mm] recommended for removal or installation purposes

Figure 2

## Position and Level the Tumble Dryer

1. Remove lint panel door, and unscrew the four shipping bolts (one at each corner).
2. Remove tumble dryer from pallet.

**NOTE: DO NOT discard shipping bolts, they are used as machine leveling legs.**

3. Remove four nuts from the literature package, and screw one fully on to each leveling leg.

4. Screw the four leveling legs (bolts) back into the level adjusting fittings from the bottom.
5. Slide tumble dryer to its permanent location. Adjust the leveling legs until the unit is level, or no more than 0.13 inch [3.3 mm] higher in the front. Refer to *Figure 3*. Tumble dryer must not rock. Lock leveling legs with nuts previously installed.

**NOTE:** The front of the tumble dryer should be slightly higher than the rear (approximately 0.13 inch [3.3 mm]). This will prevent the clothes, while tumbling, from wearing on the door glass gasket.

**IMPORTANT:** Keep tumble dryer as close to floor as possible. The unit must rest firmly on floor so weight of tumble dryer is evenly distributed.

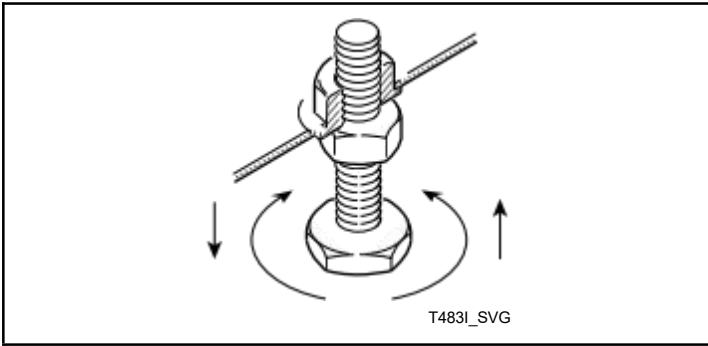

Figure 3

### Fifth Leveling Leg

The stacked tumble dryer has a fifth leveling leg which is shipped in the up position. The fifth leveling leg **MUST BE** installed properly on the lower left side of the blower housing to stabilize the tumble dryer. Refer to *Figure 4*.

After leveling with the four cabinet leveling legs, lower the fifth leveling leg so it contacts the floor, and then secure the screws.

	<b>CAUTION</b>
<p>The stacked tumble dryer has a 5th leveling leg on the blower housing. It is very important to properly adjust this leg. Unit is back heavy and could rock or tip.</p>	
W250R1	

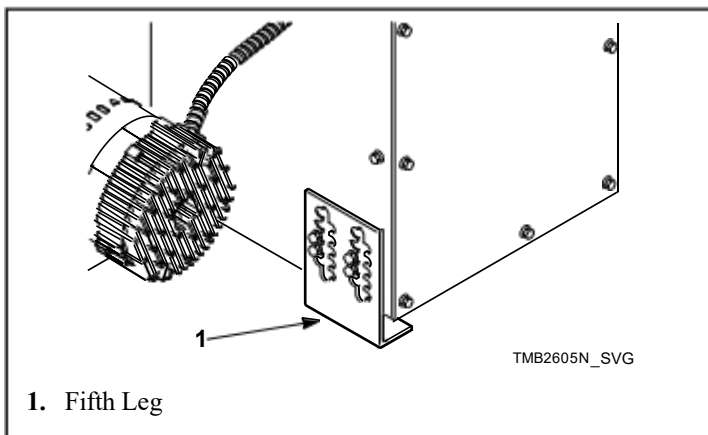

Figure 4

## Fire Suppression System (Optional Equipment)

	<b>WARNING</b>
<p><b>ELECTRICAL SHOCK HAZARD.</b> Electrical shock can result in death or serious injury. If the water dispensing system is activated, do not attempt to operate the tumble dryer. If the water dispensing system is activated, have the tumble dryer inspected by a qualified agency before operating the tumble dryer.</p>	
W879R1	

**IMPORTANT:** Main supplies of electricity and water to the tumble dryer should remain on at all times for the fire suppression system to work.

### Check Local Codes and Permits

Call your local water company or the proper municipal authority for information regarding local codes.

**IMPORTANT:** It is your responsibility to have **ALL** plumbing connections made by a qualified professional to assure that the plumbing is adequate and conforms to local, state, and federal regulations or codes. **IMPORTANT:** It is the installation or owner's responsibility to confirm that the necessary or required water, water pressure, pipe size, or connections are provided. Manufacturer assumes no responsibility if the fire suppression system is not connected, installed, or maintained properly.

### Water Requirements

**IMPORTANT:** Water must be supplied to the fire suppression system, or the fire suppression system will not operate as intended.

To ensure the fire suppression system operates properly:

- Water supply requirements: 3/4 inch hose connections providing 15 gpm [57 lpm] minimum flow; Water pressure 20 psi [138 kPa] minimum, 120 psi [827 kPa] maximum; water temperature 40°F [4.5°C] minimum, 120°F [49°C] maximum must be maintained at all times.
- Electric power to the tumble dryer must be provided at all times.
- Perform preventative maintenance checks every month. Refer to Operation/Maintenance Manual.

**NOTE:** Water pressure under 20 psi [138 kPa] will cause low flow at water solenoid valve.

If the rear of the tumble dryer or the water supply is located in an area where it will be exposed to cold/freezing temperatures, provisions must be made to protect these water lines from freezing.

**IMPORTANT:** Temperature of the water supply must be kept between 40°F and 120°F [4.5°C and 49°C]. If water in the supply line or water solenoid valve freezes, the fire suppression system will not operate.

**IMPORTANT:** If temperature sensors inside the tumble dryer register a temperature below 40F° [4.5°C], the fire suppression system control will lock out. This feature protects against operation of the tumble dryer with a possible frozen water supply. Only when the temperature sensors register a temperature 40F° [4.5°C] or above will the machine reset for operation.

For installations where the tumble dryer must operate below 40°F [4.5°C], a cold weather fire suppression system relocation kit (part no. 44340301) is available. Refer to the instructions provided in the kit for proper installation.

**IMPORTANT:** Flexible supply line/coupling must be used. Solenoid valve failure due to hard plumbing connections will void the warranty. It is recommended that a filter or strainer be installed in the water supply line.

### Water Connections

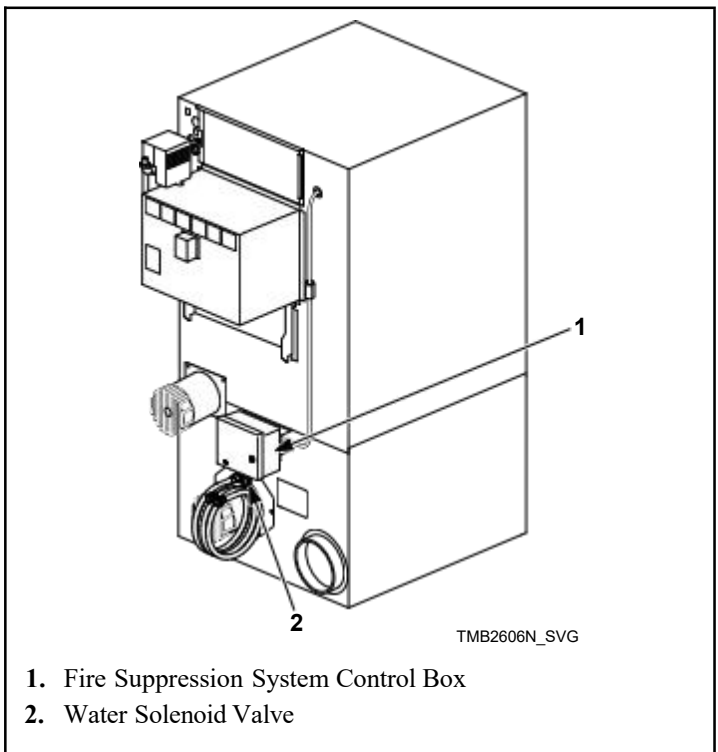

1. Fire Suppression System Control Box
2. Water Solenoid Valve

Figure 5

To connect the two hoses (supplied with tumble dryer), insert rubber washers (from literature pack) in water inlet hose couplings. Refer to *Figure 6*.

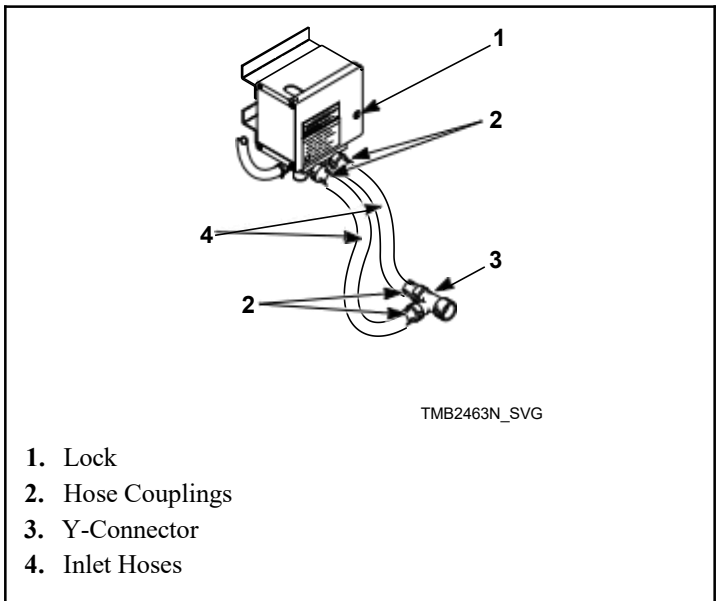

1. Lock
2. Hose Couplings
3. Y-Connector
4. Inlet Hoses

Figure 6

Connect inlet hoses to water supply. Flush the lines for approximately two minutes to remove any foreign materials that could clog the screens in the water mixing valve. This is especially important when installing a tumble dryer in a newly constructed or renovated building. Then connect the hoses to the Y-connector;



## WARNING

**Electrical shock hazard. Can cause death or serious injury. If the water dispensing system is activated do not attempt to operate the dryer. If the water dispensing system is activated have the dryer inspected by a qualified agency before operating the dryer.**

- **CALL THE FIRE DEPARTMENT.**
- **DO NOT** disconnect electric power to the dryer.
- **DO NOT** disconnect water to the dryer.
- **DO NOT** touch the dryer.

W932

Connect tumble dryer to a backflow preventer (vacuum breaker) before connecting to the public water main in all countries where local regulations require specific water approval certificates.

Two hoses and a Y-connector are provided with the tumble dryer to allow for connection of water supply to tumble dryer. **DO NOT** reuse old hose sets. The water connections are made to the water solenoid valve, located on the rear of the tumble dryer. The Y-connector provides a single female hose connection (Standard US 3/4-11 1/2 NH thread). Refer to *Figure 5* and *Figure 6*.

connect the Y-connector to the connections at the rear of the tumble dryer.

**IMPORTANT: Thread hose couplings onto valve connections finger tight, then turn 1/4 turn with pliers. Do not cross thread or overtighten couplings.**

**IMPORTANT: Hoses and other natural rubber parts deteriorate after extended use. Hoses may develop cracks, blisters or material wear from the temperature and constant high pressure they are subjected to. All hoses should be checked on a yearly basis for any visible signs of deterioration. Any hose showing the signs of deterioration listed above should be replaced immediately. All hoses should be replaced every five years.**

**NOTE: Longer inlet hoses are available (as optional equipment at extra cost) if the hoses supplied with the tumble dryer are not long enough for installation. Order hoses as follows:**

Part No. 20617 Inlethose 8.0 feet [2.4 m]

Part No. 20618 Inlethose 10 feet [3.0 m]



## WARNING

**Electrical power must be provided to tumble dryer at all times. The fire suppression system will be inoperative if the main electrical power supply is disconnected.**

W690R1

No independent external power source or supply connection is necessary. Power to operate the fire suppression system is from the tumble dryer main power supply.

## Before Placing Tumble Dryer into Service

1. Ensure all panels and guards are in place.
2. Remove and discard wire tie from the airflowswitch so it can swing freely. Refer to Figure 12 .

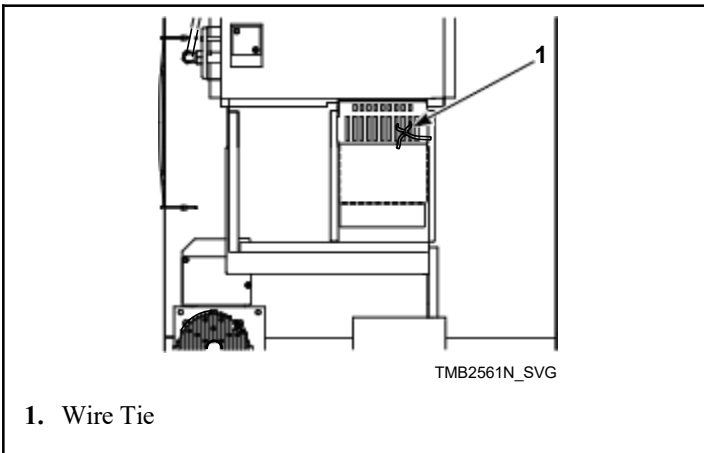

Figure 12

3. Pull out emergency stop button, if applicable.
4. Turn on electrical supply to tumble dryer.
5. Open the supply valve for gas or steam heated tumble dryers.
6. After performing the previous checks, start the tumble dryer by pressing START. (Refer to the Operating section for detailed instructions.) Release the start button and open the loading door. The cylinder should stop rotating within seven seconds after the door is opened a maximum of 0.79 inches [20 mm]. If it does not, adjust the loading door switch. Refer to Adjustments section.
7. **Gas Tumble Dryers:** Start the tumble dryer and check the burner flame. Adjust the air inlet shutter as required. Refer to Adjustments section.

**IMPORTANT: The electronic ignition system will attempt to light the gas by sparking for the “trial for ignition” period. If gas does not ignite within this period, the ignition control will go into a safety lock-out and the valve will no longer open until the control is reset. On CSA models, the electronic ignition system is automatically reset. On AGA and IEC models the electronic ignition system must be manually reset. The control will pause the cycle and indicate that the ignition control needs to be reset. To reset the ignition control, press start key on the control while the access panel is open. The control will then prompt for the start key to be pressed again to restart the cycle. On all models, ignition lockout may occur due to air in the gas line or the gas shut-off valve being in the OFF position. If the air is bled out of the gas line, the gas shut-off valve is in the ON position, the gas service is properly connected and the tumble dryer continues to have heater errors and/or prompts for the ignition control to be reset, remove the tumble dryer from service.**

8. Load the cylinder with a full load of clean rags and run to remove oil or dirt from cylinder.
9. Check the airflowswitch operation by opening the lint panel; be sure to remove shipping wire tie from airflowswitch prior to operation. Temporarily tape down the lint panel safety switch located behind the upper left corner of the lint panel. The heating systems should shut off when the lint panel is opened a maximum of 1.5 inches [ 38 mm] .

The airflowswitch operation may be affected by shipping wire tie still in place, lack of make-up air, or an obstruction in the exhaust duct. These should be checked. If there is a problem, contact an authorized service person.

**IMPORTANT: Remove tape from the lint panel safety switch before proceeding to the next step.**

	<h2>WARNING</h2>
<p><b>Do not operate tumble dryer if airflow switch is faulty. An explosive gas mixture could collect in tumble dryer if airflow switch does not operate properly.</b></p>	
<small>W407R1</small>	

10. Clean cylinder by running a load of wet rags on one maximum heat cycle.

# Exhaust Requirements

## Exhaust Requirements

	<b>CAUTION</b>
<p><b>Risk of fire. A clothes dryer produces combustible lint. Exhaust outdoors. Consult technical instructions for detailed exhaust specifications.</b></p>	
W933	

	<b>WARNING</b>
<p><b>To reduce the risk of fire, DO NOT use plastic or thin foil ducting to exhaust the tumble dryer.</b></p>	
W773R1	

	<b>WARNING</b>
<p><b>To reduce the risk of fire and accumulation of combustible gases, DO NOT exhaust tumble dryer air into a window well, gas vent, chimney or enclosed, unventilated area such as an attic wall, ceiling, crawl space under a building, or concealed space of a building.</b></p>	
W059R1	

## Layout

Whenever possible, install tumble dryers along an outside wall where duct length can be kept to a minimum, and make-up air can be easily accessed. Construction must not block the airflow at the rear of the tumble dryer. Doing so would prevent adequate air supply to the tumble dryer combustion chamber.

## Make-Up Air

A tumble dryer is forced air exhausted and requires provisions for make-up air to replace air exhausted by tumble dryer.

**IMPORTANT: Do not obstruct flow of combustion and ventilation air.**

<b>Required Make-Up Air Opening (to the outside) for Each Tumble Dryer, in.<sup>2</sup> [ cm<sup>2</sup>]</b>	
Model	Opening
Standard 025/030 Series	110 [710]
Eco 025 Series	65 [420]
Standard 035/055 Series	144 [930]
Eco 035 Series	120 [775]
Standard BT30 Series	220 [1,420]
Eco BT30 Series	180 [1,160]
BT50 Series	288 [1,860]

Make-up air openings with louvers will restrict airflow. The opening must be increased to compensate for area taken up and restrictions created by louvers. Contact the louver manufacturer for the exact specifications.

Make-up air openings in rooms containing tumble dryer(s) and/or gas fired hot water heater or other gravity vented appliances must be increased sufficiently to prevent downdrafts in any of the vents when all tumble dryers are in operation. Do not locate gravity vented appliances between tumble dryer(s) and make-up air openings. If it is necessary to duct make-up air to tumble dryer(s), increase area of duct work by 25% to compensate for restrictions in air movement.

## Venting

	<b>WARNING</b>
<p><b>To reduce the risk of fire due to increased static pressure, we do not recommend installation of in-line secondary lint filters or lint collectors. If secondary systems are mandated, frequently clean the system to assure safe operation.</b></p>	
W749	

**IMPORTANT:** Installing in-line filters or lint collectors will cause increased static pressure. Failure to maintain the secondary lint system will decrease tumble dryer efficiency and may void machine warranty.

For maximum efficiency and minimum lint accumulation, tumble dryer air must be exhausted to the outdoors by the shortest possible route.

Proper sized exhaust ducts are essential for proper operation. All elbows should be sweep type. Exhaust ducts must be assembled so the interior surfaces are smooth, so the joints do not permit the accumulation of lint. **DO NOT** use plastic, thin foil or Type B flexible ducts - rigid metal ducts are recommended. Use exhaust ducts made of sheet metal or other noncombustible material. **DO NOT** use sheet metal screws or fasteners on exhaust pipe joints which extend into the duct and catch lint. Use of duct tape or pop-rivets on all seams and joints is recommended, if allowed by local codes.

Verify that old ducts are thoroughly cleaned out before installing new tumble dryer(s).

	<b>WARNING</b>
<p><b>Improperly sized or assembled ductwork causes excess back pressure which results in slow drying, lint collecting in the duct, lint blowing back into the room, and increased fire hazard.</b></p>	
W355	

**NOTE:** Exhaust ducts must be constructed of sheet metal or other noncombustible material. Such ducts must be equivalent in strength and corrosion resistance to ducts made of galvanized sheet steel not less than 0.02 inches [0.50 mm] thick.

Where the exhaust duct pierces a combustible wall or ceiling, the opening must be sized per local codes. The space around the duct may be sealed with noncombustible material. Refer to *Figure 14*.

**IMPORTANT:** For best performance provide an individual exhaust duct for each tumble dryer. Do not install a gas water heater in a room containing tumble dryers. It is better to have the water heater in a separate room with a separate air inlet.

**NOTE:** Proper venting will ensure that any condensate is subsequently re-evaporated and discharged.

**NOTE:** On IEC approved tumble dryers where it may be required, an exhaust adapter is available to convert to female outlet. Contact local distributor or manufacturer.

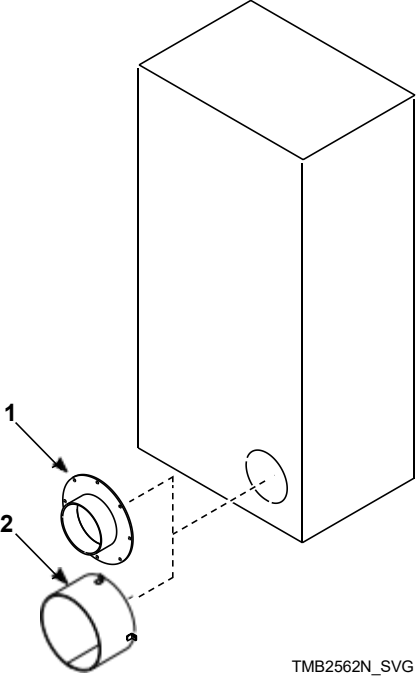

TMB2562N\_SVG

1. 25, 30, 35, 55 Models
2. Not Applicable

Figure 13

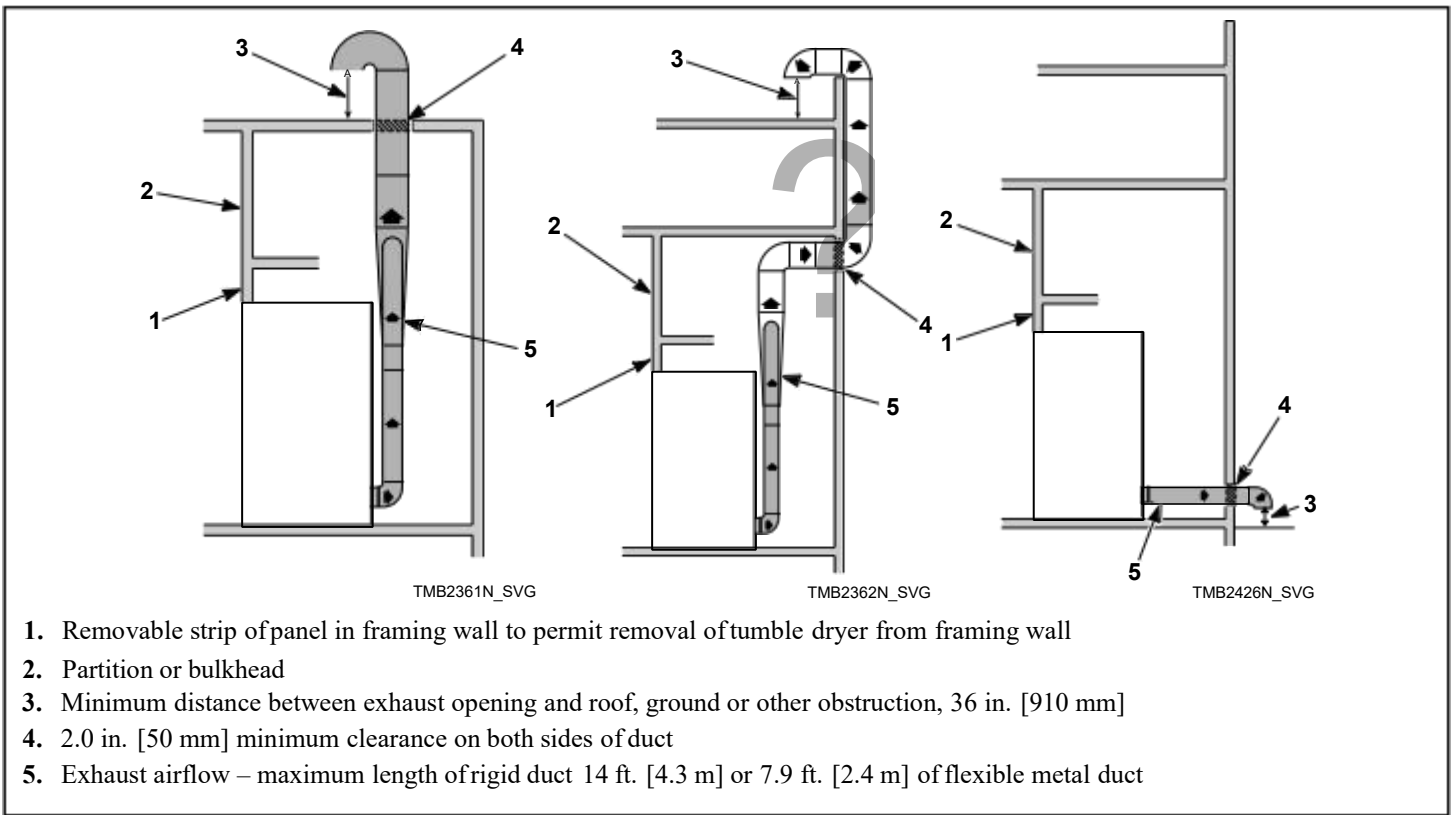

Figure 14

**NOTE: Do not install wire mesh or screen in exhaust duct opening to avoid lint build-up or impacting proper discharge of air from tumble dryers.**

**NOTE: Where exhaust duct pierces a combustible wall or ceiling, the opening must be sized per local codes.**

**NOTE: Inside of duct must be smooth. Do not use sheet metal screws to join sections.**

**NOTE: Locate exhaust far enough away from make-up air location to prevent re-introduction.**

Consult your local building code for regulations which may also apply.

### Individual Venting

For maximum efficiency and performance, it is preferred to exhaust tumble dryer(s) individually to the outdoors.

**IMPORTANT: At no point may the cross sectional area of installed venting be less than the cross sectional area of the exhaust outlet of the tumble dryer.**

The exhaust duct must be designed so the static back pressure measured 12 inches [305 mm] from the exhaust outlet does not exceed the maximum allowable pressure specified in the Specifications and Dimensions Table or on the installation sticker on the rear of the tumble dryer.

**NOTE: Static back pressure must be measured with the tumble dryer running.**

The maximum allowable length venting is 14 feet [4.3 m] and two 90° elbows or equivalent. If the equivalent length of a duct required for an installation exceeds the maximum allowable equivalent length, the diameter of a round duct must be increased by 10% for each additional 20 feet [6.1 m]. Cross section area of a rectangular duct must be increased by 20% for each additional 20 feet [6.1 m]. Refer to *Table 13* to determine equivalent venting.

Duct Diameter	Equivalent Length of Rigid Straight Duct
8 in. [203 mm]	One 90° elbow = 9.3 ft. [2.8 m]
10 in. [254 mm]	One 90° elbow = 11.6 ft. [3.5 m]
12 in. [305 mm]	One 90° elbow = 14 ft. [4.3 m]
14 in. [356 mm]	One 90° elbow = 16 ft. [4.9 m]

Table 13 *continues...*

Duct Diameter	Equivalent Length of Rigid Straight Duct
16 in. [406 mm]	One 90° elbow = 18.7 ft. [5.7 m]
18 in. [457 mm]	One 90° elbow = 21 ft. [6.4 m]
Equivalent Length (meter) = 1.17 x Duct Diameter (mm)	

Table 13

Example: A 12 inch [305 mm] diameter duct's equivalent length of 14 feet [4.3 m] of duct and two 90° elbows is:

Equivalent Length

= 14 ft. [4.3 m] + (2) 90° elbows

= 14 ft. [4.3 m] + 14 ft. [4.3 m] + 14 ft. [4.3 m]

= 42 ft. [12.8 m]

With the tumble dryer in operation, airflow at any point in the duct should be at least 1200 feet/min. [366 m/min.] to ensure that lint remains airborne. If 1200 feet/min. [366 m/min.] cannot be maintained, schedule monthly inspections and cleaning of the ductwork.

**NOTE: The maximum length of a flexible metal duct must not exceed 7.9 ft. [2.4 m] as required to meet UL2158, clause 7.3.2A.**

### Manifold Venting

**IMPORTANT: Do not exhaust tumble dryers into a flue used by other appliances.**

While it is preferable to exhaust tumble dryers individually to the outdoors, a main collector duct may be used if it is sized according to *Figure 16* and *Figure 17*. This illustration indicates mini-

imum diameters, and should be increased if the collector length exceeds 14 feet [4.3 m] and two 90° elbows. The diameter of a round duct must be increased by 10% for each additional 20 feet [6.1 m]. Cross sectional area of a rectangular or square duct must be increased 20% for each additional 20 feet [6.1 m]. Refer to *Table 14* to determine equivalent ducting sizing. The collector duct may be rectangular or square in cross section, as long as the area is not reduced. Provisions **MUST** be made for lint removal and cleaning of the collector duct.

The vent collector system must be designed so the static back pressure measured 12 inches [305 mm] from the exhaust outlet does not exceed the maximum allowable pressure specified in the Specifications and Dimensions Table or on the installation sticker on the rear of tumble dryer. Static back pressure must be measured with all tumble dryers vented into the collector operating.

**NOTE: Never connect a tumble dryer duct at a 90° angle to the collector duct. Refer to *Figure 15*. Doing so will cause excessive back pressure, resulting in poor performance. Never connect two tumble dryer exhaust ducts directly across from each other at the point of entry to the collector duct.**

With the tumble dryer in operation, airflow at any point in the duct should be at least 1200 feet/min. [366 m/min.] to ensure that lint remains airborne. If 1200 feet/min. [366 m/min.] cannot be maintained, schedule monthly inspections and cleaning of the ductwork.

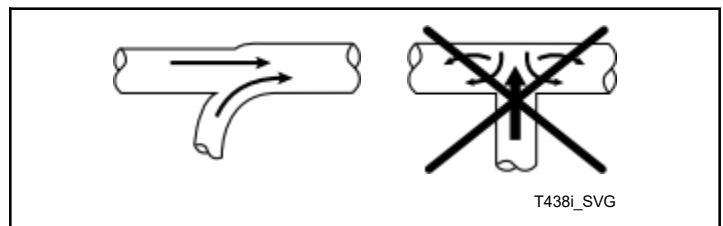

Figure 15

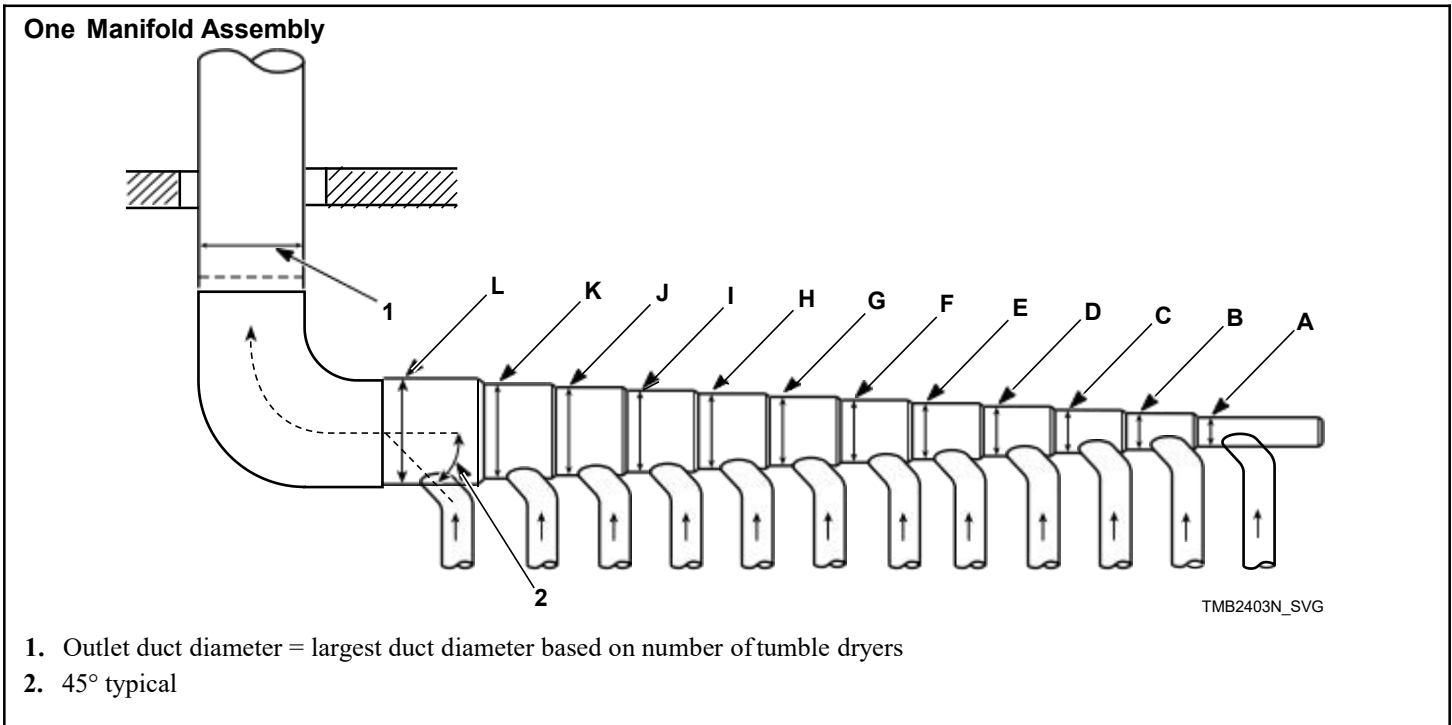

Figure 16

Duct Station	Standard Line Eco BT30 and all 030 Series	035, 055 and Standard BT30 Series	BT50 Series
A	6 in. [152 mm]	8 in. [203 mm]	10 in. [254 mm]
B	10 in. [254 mm]	12 in. [305 mm]	15 in. [381 mm]
C	12 in. [305 mm]	15 in. [381 mm]	18 in. [457 mm]
D	14 in. [356 mm]	17 in. [432 mm]	21 in. [533 mm]
E	16 in. [406 mm]	19 in. [483 mm]	24 in. [610 mm]
F	18 in. [457 mm]	21 in. [533 mm]	26 in. [660 mm]
G	19 in. [483 mm]	23 in. [584 mm]	28 in. [711 mm]
H	20 in. [508 mm]	24 in. [610 mm]	30 in. [762 mm]
I	22 in. [559 mm]	26 in. [660 mm]	32 in. [813 mm]
J	23 in. [584 mm]	27 in. [686 mm]	33 in. [838 mm]
K	24 in. [610 mm]	28 in. [711 mm]	35 in. [889 mm]
L	25 in. [635 mm]	30 in. [762 mm]	36 in. [914 mm]

Table 14

NOTE: *Table 14* represents tumble dryers with the same vent size. If multiple vent sizes are used, consult a local HVAC specialist.

NOTE: Duct clean-out recommended every 6 feet [0.18 m].

### Two Manifold Assemblies

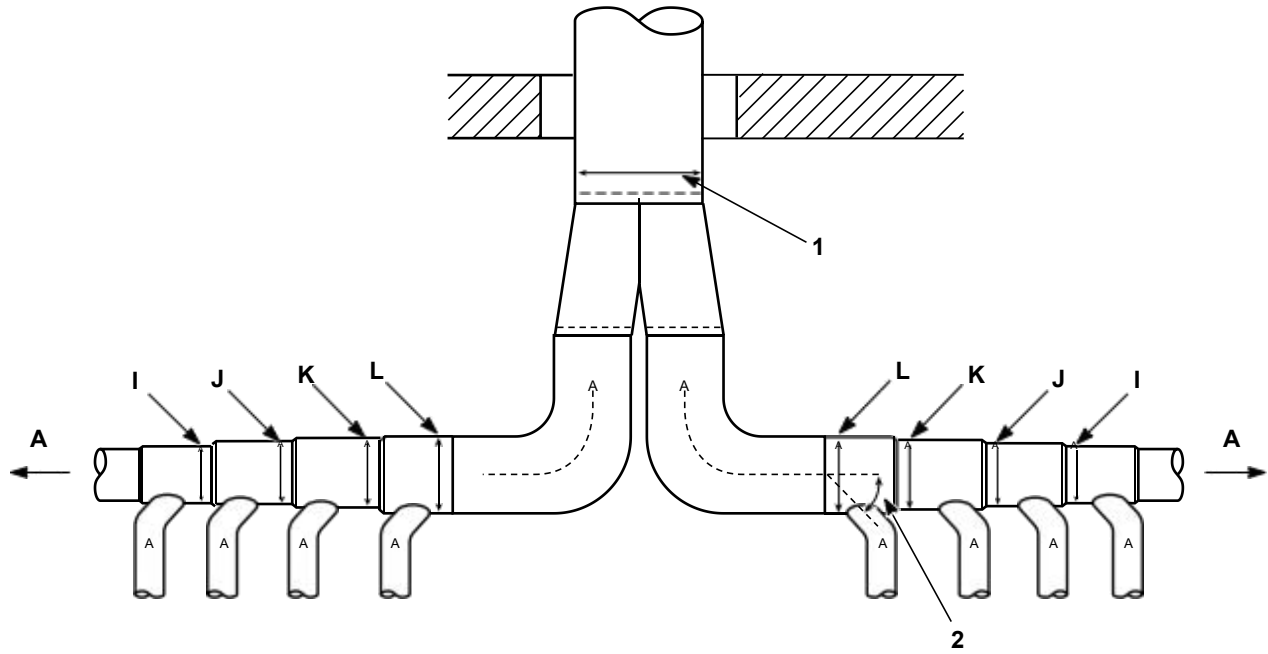

TMB2018N\_SVG

1. Outlet duct diameter = combined largest duct diameter of both sides
2. 45° typical

Figure 17

Refer to *Table 14* for measurements for each manifold.

# Gas Requirements

## Gas Requirements

	<b>CAUTION</b>
<ul style="list-style-type: none"><li>• Thoroughly test all piping for leaks before operating. All fittings and piping must be tight and supported against breakage and vibration.</li><li>• Turn off primary gas line shut off cock when not in use (overnight, weekends, holidays, etc.).</li></ul>	
W934	

	<b>WARNING</b>
<p>To reduce the risk of fire or explosion, <b>DO NOT CONNECT THE GAS LINE TO THE TUMBLE DRYER IF THE GAS SERVICE IS NOT THE SAME AS THAT SPECIFIED ON THE TUMBLE DRYER SERIAL PLATE!</b> It will first be necessary to convert the gas burner orifice and gas valve. Appropriate conversion kits are available.</p>	
W060R1	

	<b>WARNING</b>
<p>To reduce the risk of gas leaks, fire or explosion, use a new flexible stainless steel connector.</p>	
W774	

**IMPORTANT:** Any product revisions or conversions must be made by the Manufacturer's Authorized Dealers, Distributors or local service personnel.

**IMPORTANT:** The tumble dryer must be isolated from the gas supply piping system by closing its individual manual shut-off valve during any pressure testing of the gas supply piping system. Gas supply pressure must never exceed 1/2 PSI [3.45 kPa, 34.5 mbar] during leak testing. Gas supply must provide 6.5+/-1.5 inches [1.62+/-0.37 kPa, 16.17+/-3.73 mbar] with all gas appliances firing.

**NOTE:** For gas valves with a manual shut-off switch on the gas valve, the shut-off switch does not protect the valve from this pressure test. Use the individual manual shut-off valve from the gas supply piping system to protect the gas valve.

**IMPORTANT:** The installation must comply with local codes or, in the absence of local codes:

- with the latest edition of the "National Fuel Gas Code," ANSI Z223.1/NFPA 54 in the U.S.A.
- with CAN/CSA-B149.1 Natural Gas and Propane Installation Code in Canada
- In Australia and New Zealand, installation must comply with the Gas Installations Standard AS/NZS 5601 Part 1: General Installations.
- In the EU, installation must comply with the installation regulations of the country of destination.

**IMPORTANT:** For Australian models, do not remove the gas type label on the rear of the unit.

Obtain specific gas service pipe size from the gas supplier. Refer to *Table 16* and *Table 17* for general pipe size.

The following must be furnished and installed by the customer for the gas service line to each tumble dryer. Refer to *Figure 18*.

- Sediment traps
- Shut-off valves
- Supply pressure taps (1/8 NPT minimum) (refer to *Figure 18*)
- Union at gas supply connection (listed to ANSI Z21.24 and CSA 6.10)

It is important that equal pressure be maintained at all tumble dryer gas connections. This can be done by installing a 1 inch pipe gas loop to maintain equal pressure at all gas connections. Refer to *Figure 22*.

	<b>WARNING</b>
<p>To reduce the risk of fire or explosion, if the tumble dryer is to be connected to Liquefied Petroleum (L.P.) gas, a vent to the outdoors must be provided in the room where the tumble dryer is installed.</p>	
W062R1	

Before installation, check that the local distribution conditions, nature of gas and pressure, and the adjustment of the appliance are compatible.

NATURAL GAS supply pressures with all gas appliances running (tumble dryers, water heaters, space heaters, furnace, etc.):

	<b>North America Models</b>	<b>Australia Models</b>	
Maximum	10.5 in. w.c.	2.61 kPa	
Recommended	6.5 in. w.c.	1.62 kPa	
Minimum	5 in. w.c.	1.13 kPa	

An in-line pressure regulator may be required if the line pressure exceeds 10.5 water column inches [26.1 mbar, 2.61 kPa] with all gas appliances running.

PROPANE/LIQUID PETROLEUM GAS (L.P.G.) supply pressures with all gas appliances running (tumble dryers, water heaters, space heaters, furnace, etc.):

	<b>North America Models</b>	<b>Australia Models</b>	
Maximum	13 in. w.c.	3.23 kPa	
Recommended	11 in. w.c.	2.74 kPa	
Minimum	10 in. w.c.	2.49 kPa	

## How to Change Burner Orifice Size

1. Disconnect electrical power from tumble dryer. Close gas shut-off valve to tumble dryer. Refer to *Figure 19* .



### WARNING

**When converting the tumble dryer to a different gas or pressure, first verify that the supply inlet pressure is equipped with a pressure regulator (located ahead of the tumble dryer) that will maintain the gas supply at the inlet pressure specified.**

W430R1

2. Remove orifice holder. Unscrew orifice holder nut near gas valve. Remove the burner orifice(s) from orifice holder. Refer to *Figure 20* .
3. Install the new, correct burner orifice(s). Refer to *Figure 21* and *Table 15* . Torque each to 9 – 10 Nm.
4. Reinstall orifice holder assembly to gas valve, making certain burner orifice(s) are inline with burner tube opening. Refer to *Figure 21* .
5. Commission tumble dryer for use.

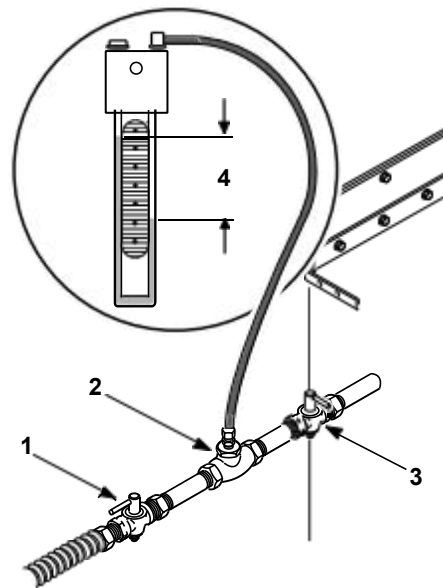

TMB2328N\_SVG

1. Gas Shut-Off Valve (Ahead of pressure tap) (Shown in open position) (Not Supplied)
2. Pressure Tap
3. Gas Shut-Off Valve (Shown in closed position) (Not Supplied)
4. Specified Local Inlet Pressure

Figure 19

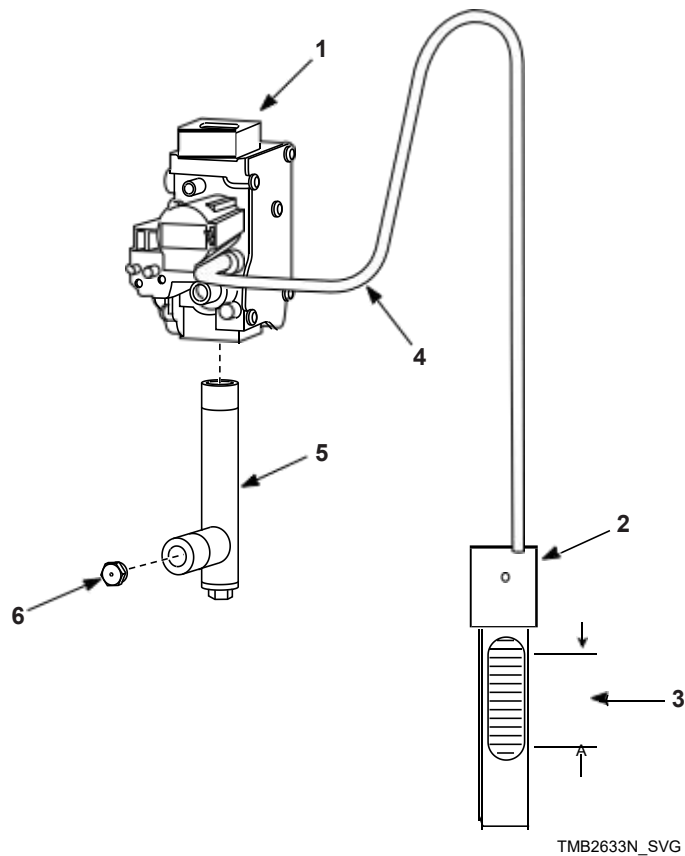

TMB2633N\_SVG

**NOTE: For IEC gas valves, attach manometer to end of orifice holder. For Australia and North America gas valves, attach manometer to the outlet pressure port on the gas valve.**

1. Gas Valve
2. Manometer
3. Required Burner Manifold Pressure
4. Connect Over Loosened Hex Pressure Tap Screw
5. Orifice Holder
6. Burner Orifice

Figure 20

### How to Adjust Gas Valve Governor/Regulator

1. Check gas burner orifice (manifold) pressure as follows. Refer to *Figure 20* .
2. Remove screw plug from pressure tap.
3. Connect a “U”-tube manometer (or similar pressure gauge) to the burner orifice (manifold) pressure tap.
4. Start tumble dryer and note pressure once flame is burning. Remove regulator cap and adjust regulator screw until the burner orifice pressure per applicable table is achieved. Replace regulator cap. Refer to *Figure 20* .
5. Commission tumble dryer for use.

### Burner Orifice



TMB2015N\_SVG

1. Size Stamped on Orifice

Figure 21

## Start-Up Procedure

Turn on gas and check all pipe connections (internal and external) for gas leaks with a non-corrosive leak detection fluid. Purge air in gas service line by operating the tumble dryers in the drying mode. If burner does not light and unit goes into lockout, press start key on the control while the access panel is open. The control will then prompt for the start key to be pressed again to restart the cycle. Repeat these steps until burner ignites. Use pipe compound, resistant to actions of L.P. gas, on all pipe threads.



## WARNING

**Check all pipe connections, internal and external, for gas leaks using a non-corrosive leak detection fluid. To reduce the risk of explosion or fire, DO NOT USE AN OPEN FLAME TO CHECK FOR GAS LEAKS! Gas connections should be checked daily for leakage.**

W924

## Gas Supply Pipe Sizing and Looping

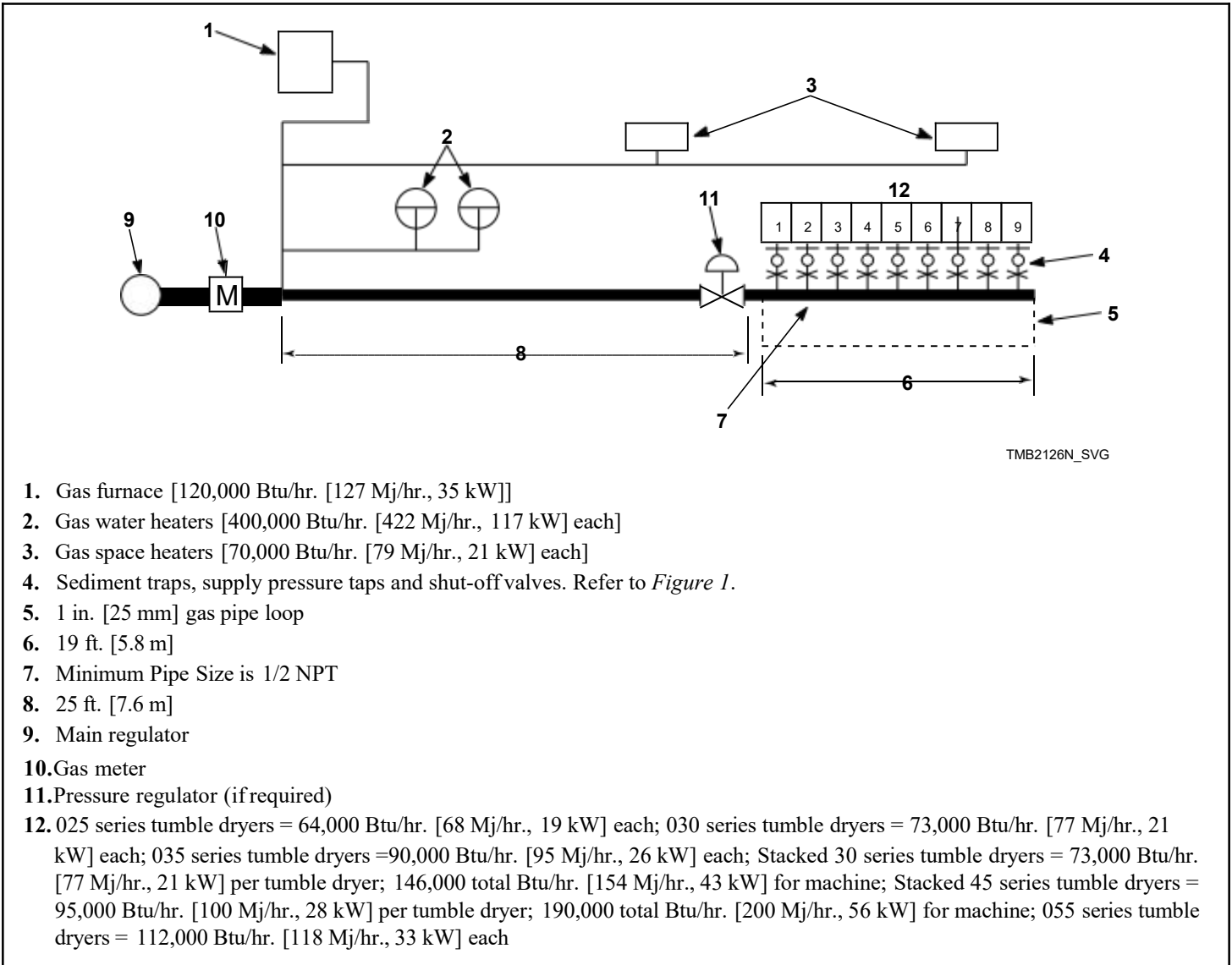

Figure 22

### SAMPLE CALCULATIONS:

Equivalent length = Total length of main gas supply pipe to the far end of the tumble dryers.  
 = 25 ft. + 19 ft. [7.6 m + 5.8 m] gas supply pipe  
 = 44 ft. [13.4 m] Total Gas Line

Total Btu/hr. = The sum of the Btu/hr. of all 030 series tumble dryers being fed by the main gas supply pipe.  
 = 9 x 73,000 [77, 21]  
 = 657,000 Btu/hr. [193 kW]

Using *Table 16*, the main supply pipe diameter should be 2 NPT.

**IMPORTANT: Gas loop piping must be installed as illustrated to equalize gas pressure for all tumble dryers connected to single gas service. Other gas using appliances should be connected upstream from loop.**

# Electrical Requirements

## Electrical Requirements

	<b>WARNING</b>
<ul style="list-style-type: none"><li>• To reduce the risk of electric shock, disconnect this appliance from the power supply before attempting any user maintenance other than cleaning the lint trap for dryers. Turning the controls to the OFF position does not disconnect this appliance from the power supply.</li><li>• To reduce the risk of fire and electric shock, check with a qualified service person for proper grounding procedures. Improper connection of the equipment grounding conductor may result in a risk of electric shock.</li><li>• Certain internal parts are intentionally not grounded and may present a risk of electric shock only during servicing. Service Personnel - Do not contact the following parts while the appliance is energized: Input/Output Board and Variable Frequency Drive, including the heat sinks.</li><li>• This appliance shall be installed in accordance with the rules in force, and dryers used only in a sufficiently ventilated space. Consult technical instruction before installation and use of this appliance.</li></ul>	
W935	

	<b>CAUTION</b>
<p>Outside of Europe, to reduce the risk of injury or component failure, if electrical supply is coming from a three phase service, DO NOT connect a "High Leg" or "Stinger Leg" to a single phase machine. On a three phase machine, if there is a "High Leg" or "Stinger Leg" it should be connected to L3.</p>	
W938	

	<b>WARNING</b>
<p>The appliance must not be supplied through an external switching device, such as a timer, or connected to a circuit that is regularly switched on and off by a utility.</p>	
W943	

**IMPORTANT:** Electrical connections must be made by a qualified electrician using data on serial plate, installation manuals and wiring diagram provided with tumble dryer and according to local codes. Install a circuit breaker as close to the tumble dryer as possible. If more than one tumble dryer is being installed, a circuit breaker must be provided for each.

**NOTE:** Connect tumble dryer to an individual branch circuit not shared with lighting or other equipment.

**NOTE:** 3 Phase Tumble Dryers Only - Do not use fuses to avoid the possibility of "single phasing" and causing premature failure of the motors.

	<b>WARNING</b>
<p>In case of servicing (or putting the tumble dryer out of order), disconnect the tumble dryer from the main supply by switching off the circuit breaker.</p>	
W796	

## Wiring Diagram

**NOTE:** Wiring diagram location: inside electrical box.

The wiring diagram part number is in the lower portion of the electrical data on the serial plate.

## Wiring for Central Pay

Applicable for the following control suffixes (position 7 and 8 of the model number): BL, NL, VL and WL.

**IMPORTANT:** Tumble dryers may have one of two types of central pay configurations: a 12vDC self-contained version or an unpowered version requiring a customer-supplied power source and resistor. Refer to Central Pay Option diagram provided with tumble dryer for specifications. Incorrect application may cause component damage.

### System Connections

Connection to central pay systems will be made in the rear junction box of the tumble dryer. For BT30 and BT50 models, connection for both the lower control and upper control will be made in the upper junction box.

Locate the harness with Black, Red, White with Red Stripe and Orange with Black Stripe wires. For BT30 and BT50 models, the upper and lower harness can be identified by a yellow label on the harness tubing indicating "UPPER" and a white label on the harness tubing indicating "LOWER".

The wire colors will be the same regardless of control type. Splice the after-market central pay system wires to the tumble dryer control wire harness as follows.

Wire Colors	Description
Red	Start Pulse Signal Input
Black	Start Pulse Signal Input
White with Red Stripe	"Machine Available" Signal Output
Orange with Black Stripe	"Machine Available" Signal Output

### Start Pulse Requirements

All control types will consider a pulse valid if it is between 10 and 1000 milliseconds in length, with a minimum of 25 milliseconds between pulses.

## Grounding Instructions

**NOTE: To ensure protection against shock, this machine MUST be electrically grounded in accordance with the local codes, or in the absence of local codes, with the latest edition of the National Electrical Code ANSI/NFPA No. 70. In Canada the electrical connections are to be made in accordance with CSA C22.1 latest edition Canadian Electrical Code, or local codes. Electrical work should be done by a qualified electrician.**

This machine must be grounded. In the event of malfunction or breakdown, grounding will reduce the risk of electric shock by providing a path of least resistance for electric current. This machine must be connected to a grounded metal, permanent wiring system; or an equipment grounding conductor must be run with

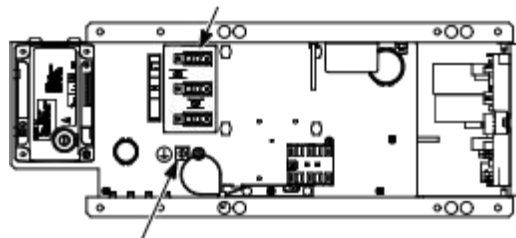

the circuit conductors and connected to the appropriate ground location.

- Metal conduit and/or BX cable is not considered ground.
- Connecting the Neutral from the electrical service box to the tumble dryer ground screw does not constitute a ground.
- A dedicated ground conduit (wire) must be connected between the electrical service box ground bar and machine ground screw.

	<b>WARNING</b>
<p><b>To reduce the risk of electrical shock, de-energize the electrical circuit being connected to the tumble dryer before making any electrical connections. All electrical connections should be made by a qualified electrician. Never attempt to connect a live circuit.</b></p> <p style="text-align: right;">W409R1</p>	

	<b>CAUTION</b>
<p><b>Label all wires prior to disconnection when servicing controls. Wiring errors can cause improper and dangerous operation. Verify proper operation after servicing.</b></p> <p style="text-align: right;">W071</p>	

# Adjustments

## Adjustments



### WARNING

To reduce the risk of electric shock, fire, explosion, serious injury or death:

- Disconnect electric power to the tumble dryer before servicing.
- Close gas shut-off valve to gas tumble dryer before servicing.
- Close steam valve to steam tumble dryer before servicing.
- Never start the tumble dryer with any guards/panels removed.
- Whenever ground wires are removed during servicing, these ground wires must be reconnected to ensure that the tumble dryer is properly grounded.

W002R1

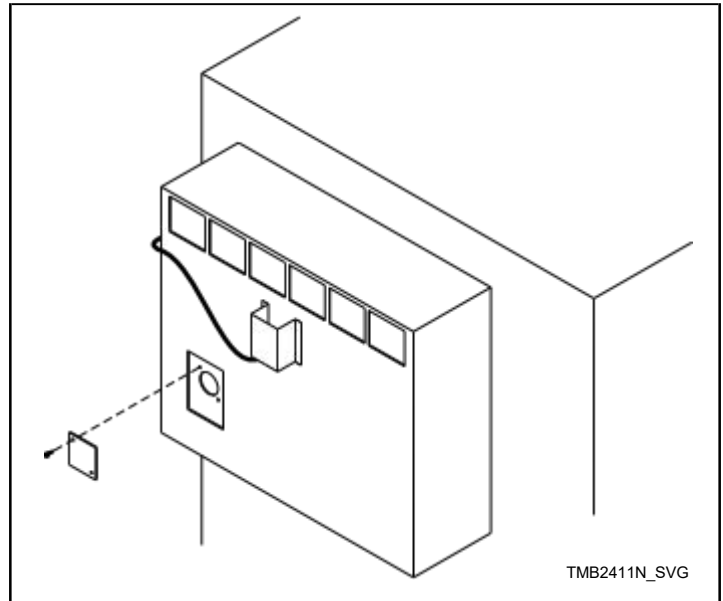

Figure 25

## Gas Burner Air Shutter

**NOTE: Air inlet shutters on the burner must be adjusted so sufficient air is metered into the system for proper combustion and maximum efficiency. Before adjusting the inlet shutters be sure that all lint is removed from lint compartments and lint screen.**

Air shutter adjustments will vary from location to location and will depend on the vent system, number of units installed, make-up air and line gas pressure. Opening the shutter increases the amount of primary air supplied to the burner while closing the shutter decreases the primary air supply. Adjust air shutter as follows:

Refer to *Figure 25*.

1. Remove the burner inspection hole plate.

2. Start the tumble dryer and check the flame pattern. If the flame pattern is straight up, insufficient air is flowing through the tumble dryer. A flame pattern that flares to the right and left indicates no air is flowing through the tumble dryer. Correct air and gas mixture is indicated if the flame pattern is primarily blue, with small yellow tips, and bends to the right of the heater section. Too little air is indicated if the flame is yellow, lazy and smokey. (A whistling sound from burner could also be caused by an improper air shutter setting.)
3. To adjust the air shutter, loosen air inlet shutter adjusting screw.
4. Open or close air shutter as necessary to obtain proper flame intensity.
5. After air shutter is adjusted for proper flame, tighten air shutter adjusting screw securely.

## Airflow Switch

The airflow switch is set at the factory for proper operation. No adjustment necessary.

The airflow switch operation may be affected by shipping wire tie still in place, lack of make-up air, or an obstruction in the exhaust duct. These should be checked and the required corrective action taken.



### WARNING

The tumble dryer must not be operated if the airflow switch does not operate properly. Faulty airflow switch operation may cause an explosive gas mixture to collect in the tumble dryer.

W072R1

**IMPORTANT:** Airflow switch vane must remain closed during operation. If it opens and closes during the drying cycle, this indicates insufficient airflow through the tumble dryer. If switch remains open, or pops open and closed during the cycle, the heating system will shut off. The cylinder and fan will continue to operate even though the airflow switch is indicating insufficient airflow.

**NOTE:** To properly mount the airflow switch bracket, or in case of a load not drying, the airflow switch bracket may need to be checked for proper alignment. Be sure the locator pins are securely in their respective holes before tightening the bracket mounting screws. This will assure proper alignment of the airflow switch arm in the channel of the airflow switch bracket and prevent binding of the arm.

## Loading Door Switch

The door switch should be adjusted so the cylinder stops when door is opened 0.79 inches [20 mm]. This switch is a normally open switch and is closed by the switch actuator when the door is closed. If adjustment is required, refer to *Figure 27* and proceed as follows:

1. Close door and start tumble dryer, slowly open loading door. Cylinder and heat system should shut off when door is open 0.79 inches [20 mm].
2. Slowly close the loading door. When door is 0.79 inches [20 mm] or less from being fully closed, the door switch actuating bracket (located on the door) should depress the button and the switch arm with an audible "click."
3. If the actuating bracket does not operate the switch at the appropriatedoor closure, bend the actuating switch arm in or out to achieve proper actuation.

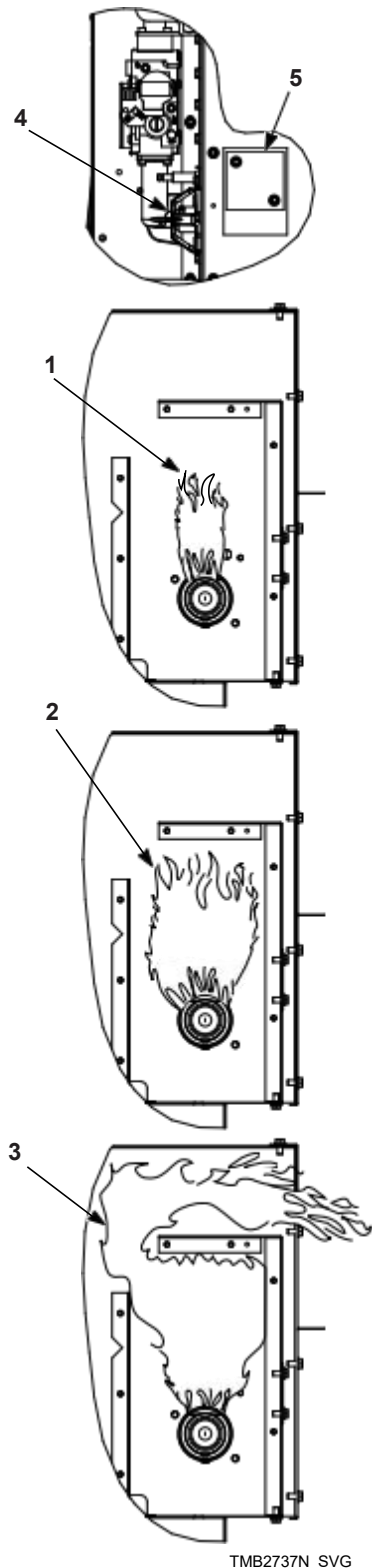

TMB2737N\_SVG

1. Proper Airflow
2. Insufficient Airflow
3. No Airflow
4. Air Shutter Adjusting Screw
5. Burner Inspection Hole

Figure 26

## Manual Resettable Thermostat

**NOTE:** The manual resettable thermostat is located as follows: 025-030-035-055 - inside access panel on rear of machine near blower motor. BT30-BT50 - on blower housing top surface behind rear guard.

If thermostat trips, contact a qualified service technician.

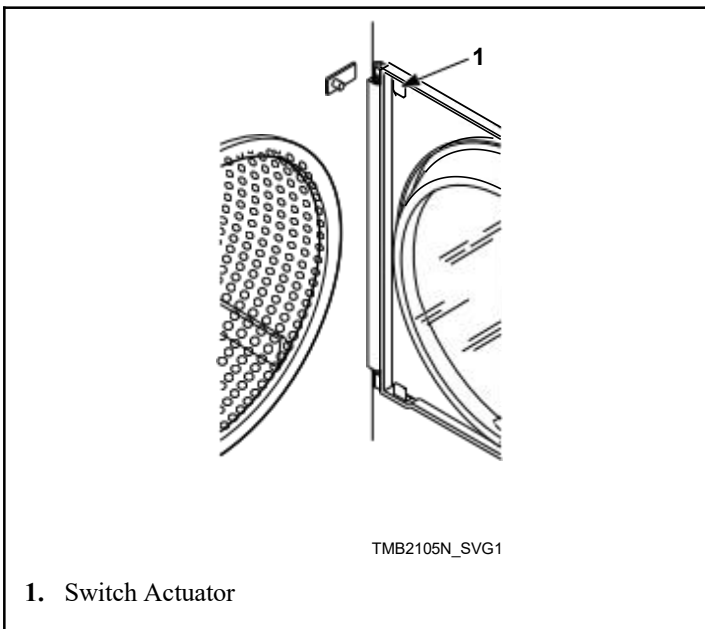

1. Switch Actuator

Figure 27

## Door Strike

The door strike must be adjusted to have sufficient tension to hold loading door closed against force of the load tumbling against it. There is proper adjustment of pull force when 8 to 15 pounds [35.6 N – 66.7 N] is required to open door.

If adjustment is required, refer to *Figure 28* and proceed as follows:

1. To adjust, open door, loosen acorn nut, and turn door strike screw in or out as required.
2. Retighten acorn nut.

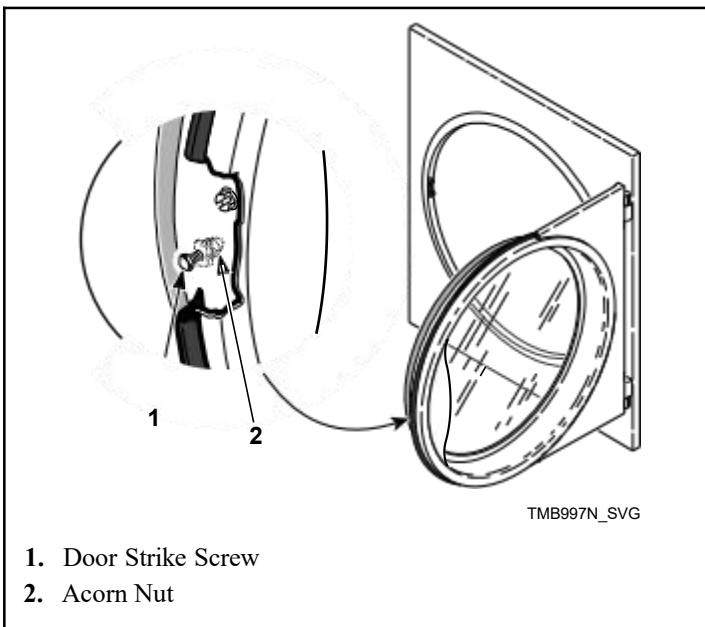

1. Door Strike Screw  
2. Acorn Nut

Figure 28

# Removing Tumble Dryer from Service

1. Turn off electrical supply external to machine.
2. Turn off gas supply external to machine.
3. Turn off manual gas shut-off valve on machine.
4. Turn off steam supply external to machine.
5. Remove all electric, gas and steam connections.

# Maintenance

Routine maintenance maximizes operating efficiency and minimizes downtime. The maintenance procedures described below will prolong the life of the machine and help prevent accidents.

	<b>WARNING</b>
<b>Sharp edges can cause personal injury. Wear safety glasses and gloves, use proper tools and provide lighting when handling sheet metal parts.</b>	
W366R1	

	<b>CAUTION</b>
<b>Replace all panels that are removed to perform service and maintenance procedures. Do not operate the machine with missing guards or with broken or missing parts. Do not bypass any safety devices.</b>	
SW019	

Follow local codes for proper advise on laundering infected garments.

The following maintenance procedures must be performed regularly at the required intervals.

## Daily

**IMPORTANT: Replace all panels that are removed to perform maintenance procedures. Do not operate the machine with missing guards or with broken or missing parts. Do not bypass any safety devices.**

	<b>WARNING</b>
<b>Do not spray the machine with water. Short circuiting and serious damage may result.</b>	
W782	

**IMPORTANT: Door lock should be checked daily to ensure proper operation. Also check that all safety and instruction stickers are on the machine. Any missing or illegible safety instructions stickers should be replaced immediately.**

## Beginning of Day

1. Inspect the door interlock before starting operation.
  - a. Attempt to start the machine with the door open. The machine should not start.
  - b. Close the door without locking it and start the machine. The machine should not start.

- c. Attempt to open the door while the cycle is in progress. The door should not open.

If the door lock and interlock are not functioning properly, disconnect power and call a service technician.

2. Check the machine for leaks.
  - a. Start an unloaded cycle to fill the machine.
  - b. Verify that door and door gasket do not leak.
  - c. Verify that the drain valve is operating and that the drain system is free from obstruction. If water does not leak out during the first wash segment, the drain valve is closed and functioning properly.
3. Inspect the water inlet valve hose connections on the back of the machine for leaks.
4. Inspect the chemical connections for machines equipped with an automatic chemical supply system by inspecting all connections and chemical hoses for leaks or cracks.

	<b>WARNING</b>
<b>To reduce the risk of electrical shock, serious injury or death, disconnect the electrical power to washer-extractor before examining the wiring.</b>	
W636	

5. If applicable, inspect the steam hose connections for leaks.
6. Ensure all panels and guards are properly installed.

## End of Day

1. Clean the wash drum, door glass, and door gasket of residual detergent and all foreign matter.
2. Clean the chemical dispenser, flushing with clean water.
3. Clean the machine's exposed surfaces with all-purpose cleaner.

**IMPORTANT: Use only isopropyl alcohol to clean graphic overlays. DO NOT use ammonia based or vinegar-based cleans on overlays.**

**NOTE: Unload the machine promptly after each completed cycle to prevent moisture buildup. Leave loading door and dispenser lid open at the end of each completed cycle to allow moisture to evaporate.**

4. Leave the loading door and dispenser lid open to allow moisture to evaporate.

**NOTE: Unload the machine promptly after each completed cycle to prevent moisture buildup.**

5. Shut off water supply.

## Monthly



### WARNING

To reduce the risk of electrical shock, serious injury or death, disconnect the electrical power to washer-extractor before examining the wiring.

W636

1. Inspect the electrical connections for looseness. Tighten as required after disconnecting power.
  - a. Verify that insulation is intact on all external wires and that all connections are secure. If bare wire is evident, call a service technician.
2. Clean inlethose filter screens.
  - a. Turn water off and allow valve and water line to cool, if necessary.
  - b. Unscrew inlethose from the faucet and remove filter screen.
  - c. Clean with soapy water and reinstall. Replace if worn or damaged.
  - d. Repeat procedure with the filter located inside the valve at the back of the machine.

**NOTE: All filter screens should be replaced every five years.**

3. If applicable, clean the customer-supplied steam filter. Refer to *Figure 65*.
  - a. Turn off steam supply and allow time for the valve to cool.
  - b. Unscrew cap.
  - c. Remove element and clean.
  - d. Replace element and cap.

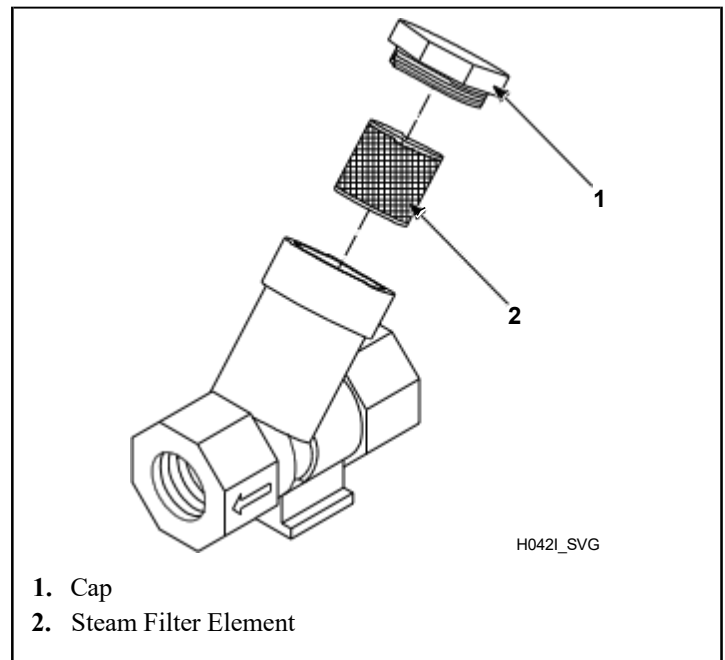

1. Cap
2. Steam Filter Element

Figure 65

4. For electric heat models only, inspect heating elements for excess debris by rotating basket to view them through its perforations. Remove drain valve hose to access and clear debris with pliers. Replace element(s) if necessary.

**NOTE: Lint buildup may take several months to occur. Inspect heating elements a minimum of every 6 months.**

5. **For 80 and 100 pound [36.3 and 45.4 kg] capacity models only** : Lubricate the barings each month or after every 200 hours of operation. Visually inspect grease line for air pockets, purging air pockets as necessary.

The grease must have the following characteristics:

- NLGI Grade 2
- Lithium-based
- Water-insoluble
- Anti-rusting
- Anti-oxidizing
- Mechanically stable

The grease must have adequate base oil viscosity with one of the following ratings:

- ISO VG 150 (709–871 SUS at 100°F [135–165 cSt at 40°C] )
- ISO VG 220 (1047–1283 SUS at 100°F [198–242 cSt at 40°C] )
- An SAE 40 rating is also acceptable as long as the cSt or SUS values are within the specified ranges.

Pump the grease gun slowly, permitting only 2 strokes.

**NOTE: Do not pump the grease gun until grease comes out of the bearing housing. This can result in over lubrication, causing damage to bearings and seals.**

**Yearly**

**NOTE: Disconnect power to the machine at its source before performing maintenance procedures.**

1. Remove the front panel(s) and rear access panels and inspect all hose, drain, and overflow connections/clamps for leaks. Inspect all hoses for visible signs of deterioration. Replace as necessary.
2. Inspect the belt for unusual wear, frayed edges, and improper belt tension, replacing belts and/or adjusting tensioning elements as necessary.

**NOTE: Belts must not be twisted and must be properly seated on pulleys. Belt must be centered on basket pulley within .04 inches [1 mm] .**

- a. Use the following procedures to determine if belt(s) require replacement or adjustment. Call a qualified service technician in either case.

**NOTE: Basket pulley must be rotated three (3) full turns before assessing belt tension after every adjustment.**

- **Frequency Gauge.** Tighten eyebolt top nut until the correct frequency (refer to *Table 47*) is obtained mid-span. Torque jam nut to spring bracket to  $20.6 \pm 2$  ft.-lbs. Refer to *Figure 66* .

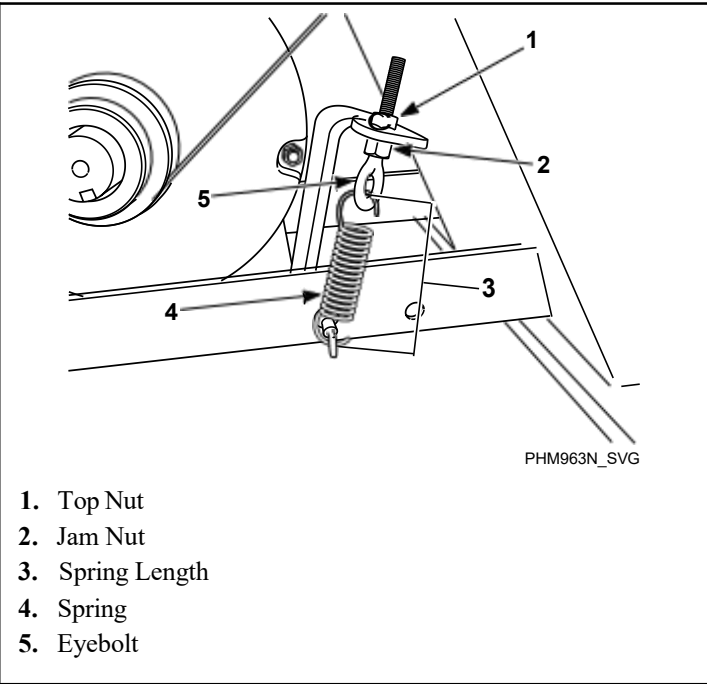

Figure 66

- **Tension Gauge.** Tighten eyebolt top nut until the proper belt gauge (refer to *Table 47*) is obtained mid-span.

Torque jam nut to spring bracket to  $20.6 \pm 2$  ft.-lbs. Refer to *Figure 66* .

- **Spring Length.** Tighten eyebolt top nut until the spring measures the correct distance between the hooks. Refer to *Table 46*. Torque jam nut to spring bracket to  $20.6 \pm 2$  ft.-lbs. Refer to *Figure 66* .

Spring Length, in. [mm]	
Model	Distance Between Hooks
20 (2 HP)	4-9/16 [116]
30	4-1/2 [114]
40	4-5/8 [117]
60	5-1/4 [133]

Table 46

- **Maintain Tension During Belt Removal.** If proper tension is achieved, tape the jam nut in place and loosen eyebolt top nut to release the belt. Replace belt and retighten eyebolt top nut back to jam nut position. Refer to *Figure 66* .

**IMPORTANT: All torque joints must remain dry (non-lubricated).**

- b. **20-60 Models:** verify the belt is centered on the basket pulley within one (1) rib. **80-100 Models:** verify the belt is within the allowable distance of .04 inch [1 mm] between the belt and the edge of basket pulley.

Belt Tension by Frequency or Belt Tension Gauge			
Model	Frequency (Hz)	Belt Tension (lbs.)	Tension Gauge (N)
20	$88 \pm 2$	$60.4 \pm 6.1$	$269 \pm 27$
30	$84 \pm 2$	$63.2 \pm 6.3$	$281 \pm 28$
40	$75 \pm 2$	$88.6 \pm 8.8$	$394 \pm 39$
60	$70 \pm 2$	$100.2 \pm 5.7$	$446 \pm 25$

Table 47

Remove any accumulated debris on or near the motor and motor variable frequency drive heat sinks, if applicable.

4. If applicable, unlock or unscrew the top cover and inspect the supply dispenser hoses and hose connections for visible signs of deterioration. Replace hoses if worn or damaged.

**NOTE: Hoses and other natural rubber parts deteriorate after extended use. Hoses may develop cracks, blisters or material wear from the temperature and constant high pressure they are subjected to.**

5. Remove any dust from all electrical components, including coin acceptors if applicable, with compressed air.
6. Inspect hardware for any loose nuts, bolts, screws.
  - a. Check the tightness of the motor spring and motor pulley hardware. Also check that the eyebolt is tightened properly.
  - b. Tighten motor mounting bolt locknuts and bearing bolt locknuts, if necessary.
  - c. Check the bearing mounting bolts to make sure they are torqued properly.
  - d. Tighten door hinges and fasteners, if necessary.
7. Place a large magnet over the normally-closed ball switch to verify the stability switch operation.
8. Ensure all panels and guards are properly reinstalled.
  - a. Verify that the drain motor shield is in place and secure, if so equipped.
9. Run factory test, reference programming manual for procedure details and components tested.

**NOTE: Refer to the Programming Manual for procedure details and components tested.**

10. Inspect all painted surfaces for exposed metal. Replace or repaint if necessary.
  - If bare metal is showing, paint with primer or solvent-based paint.
  - If rust appears, remove it with sandpaper or by chemical means. Repaint with primer or solvent-based paint.
11. Torque anchor bolts and inspect grout for cracking.

**NOTE: Refer to the Installation Manual for anchor bolt specifications.**

**IMPORTANT: All torque joints must remain dry (non-lubricated).**

12. Every 5 years replace inlet hoses, hose screens, belt, and fan filter (if applicable).

## Care of Stainless Steel

- Remove dirt and grease with detergent and water. Thoroughly rinse and dry after washing.
- Avoid contact with dissimilar metals to prevent galvanic corrosion when salty or acidic solutions are present.
- Do not allow salty or acidic solutions to evaporate and dry on stainless steel. Wipe clean of any residues.
- Rub in the direction of the polish lines or “grain” of the stainless steel to avoid scratch marks when using abrasive cleaners. Use stainless steel wool or soft, non-metal bristle brushes. Do not use ordinary steel wool or steel brushes.
- If the stainless steel appears to be rusting, the source of the rust may be an iron or steel part not made of stainless steel, such as a nail or screw.
- Remove discoloration or heat tint from overheating by scouring with a powder or by employing special chemical solutions.
- Do not leave sterilizing solutions on stainless steel equipment for prolonged periods of time.
- When an external chemical supply is used, ensure no siphoning of chemicals occurs when the machine is not in use. Highly concentrated chemicals can cause severe damage to stainless steel and other components within the machine. Damage of this kind is not covered by the manufacturer’s warranty. Locate the pump and tubing below the machine’s injection point to prevent siphoning of chemicals into the machine.

## 1、 Main functions

- Coin detection: Coin dispensers use sensors to detect the size and electromagnetic signals of incoming coins to identify their value. This coin dispenser can identify eight kinds of coins.
- Coin verification: After coins are detected, the coin dispenser will verify whether the coins meet the acceptance criteria, and invalid coins will be rejected. Counting output: it accepts the continuous counting output of the total value of the invested coins. This slot machine provides a set of counting outputs. The output mode can be NO or NC.
- Jam detection: the sensor monitors the coin jam in the receiving area and the storage area.
- Manual setting: The coin dispenser can add, delete, detect (obstacle code display), set the pulse and restore the factory setting value through the [setting key].

## 2、 the standard control line



### 3、 Description of the control interface pins of the coin-operated device

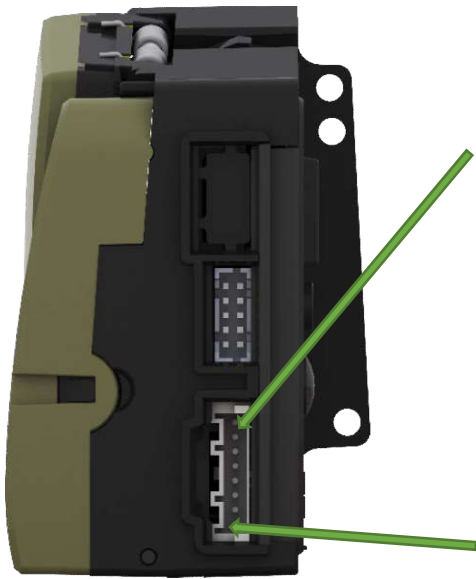



PIN	Designation	Style	Note
8	Power(Black)	Input	12V DC input
7	Power(Black)	Input	0V
6	X	X	X
5	X	X	X
4	Input (Red)	Connection	Pulse output
3	Input (Brown)	Connection	3 is connect with 7
2	X	X	X
1	X	X	X

### 4、 the operation interface (light display and setting):

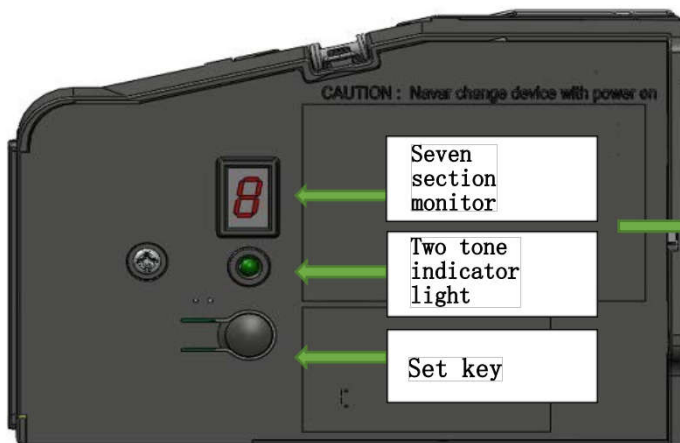
- 1.The range (value) that seven monitors can display (represent): blank, 0-9.
- 2.Enter the selection function: press the [Set Key] for less than 0.5 seconds, and the interval is less than 0.5 seconds.
- 3.Selection: Press the [Set Key] for less than 0.5 seconds.
- 4.Confirmation: Press and hold the [Set Key] for more than 2 seconds. (LED goes out)
- 5.Exit (jump off): when the operation is not completed, [wait for 12 seconds] or [press and hold the [setting key] for more than 5 seconds to leave the setting mode.



pilot lamp	status indicator
	Normal operation
	Money channel malfunction
	No power supply

## 5、 Function Description and Operation Introduction of Instruction Code

Note: The function operation of [Set Key] must be started when the green light or the red light at the money channel indicator light is on.

### Instruction 1: Money Data Collection:

Note: The whole journey (procedure) must be completed to set the coin data collection and pulse number. Operation: Press [1] and press [Set Key] and the orange light flashes.

Choose to put the collection coin code (for example, 1-10 yuan) into ten 10 yuan coins (the orange light is on).

Select the number of pulses to send ("0" means 10 pulses) and press and hold [Set Key] for two seconds (save).



**Note: If you need to reset the existing coin data, you must delete it with instruction 2 before setting the coin.**

### Instruction 2: Delete coin function:

Description: Delete the set money data.

Operation: Press the [Set Key] twice quickly and the red light flashes.

Select the coin symbol to be deleted and press it for two seconds (confirm).

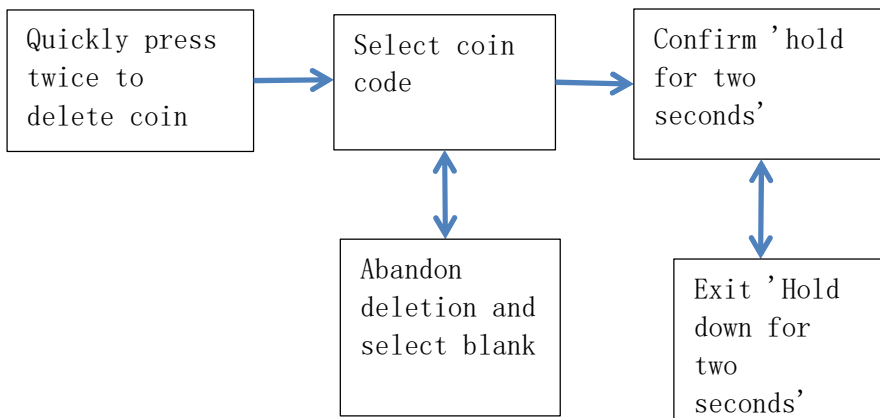

### Instruction 3: Money Road Self-test:

Description: The self-detection of the money channel and the action test of the solenoid valve can detect the induction coil and the optocoupler and display the fault code. The self-detection cycle test is carried out for 20 times.

**Operation: Press [Set Key] under [3] quickly, and the green light+(obstacle code). Red light+(obstacle code)**

The orange light+(obstacle code) lights up circularly for 20 times, and press and hold the [set key] for two seconds to exit the self-detection mode.

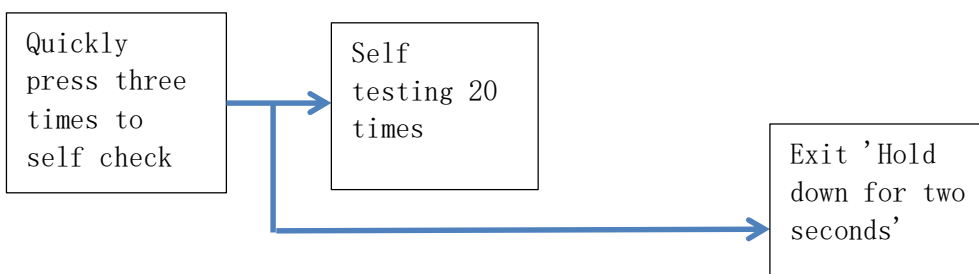

If there is no fault, 0 will be displayed, and if there is a fault, the fault code will be displayed.

Indicator light	show	explain
green	0	The light sensor is normal.
	1	Input sensor failure.
	2	The diameter sensor is faulty.
	4	
	8	
	red	3
5		
7		
9		
red	0	The coil sensor is normal.
	1	Coil 1 is faulty.
	2	Coil 2 is faulty.
	3	Coils 1 and 2 are faulty.
orange	0	The coin receiving channel sensor is normal.
	2	The coin receiving channel sensor is faulty.

Obstacle code and fault location:

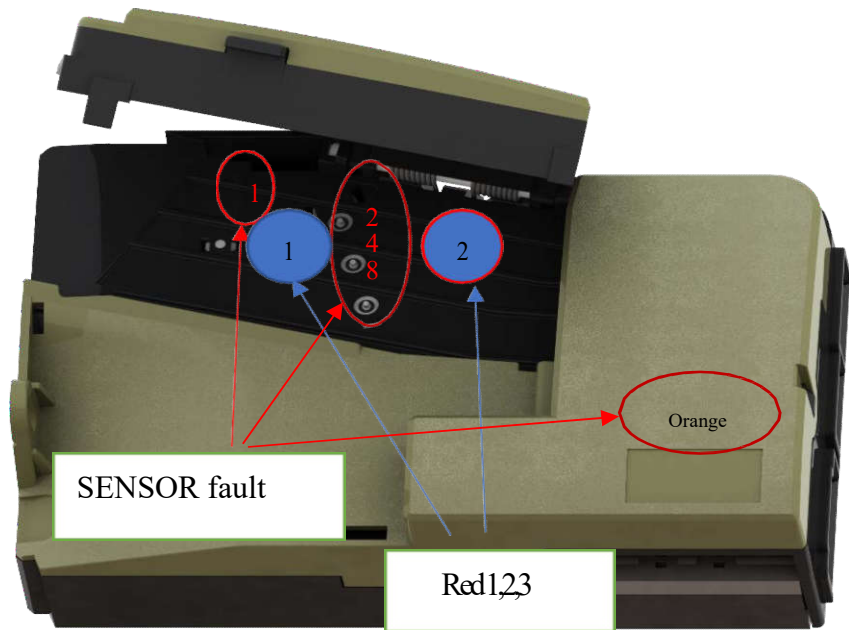

### Fault code

#### Instruction 4: Control mode setting:

Description: Control mode setting. (The default value is 1-S.Q.Laundrymode.)

Operation: Press [4] and press [Set Key] quickly, and the orange light flashes and the number is displayed as the current control mode.

Select the required control mode for confirmation (press and hold [Set Key] for two seconds).

PS [1]-S.Q. Laundry mode. [2]-S.Q. Drying mode. [3]-Fagor mode. [] Leave the setting blank.

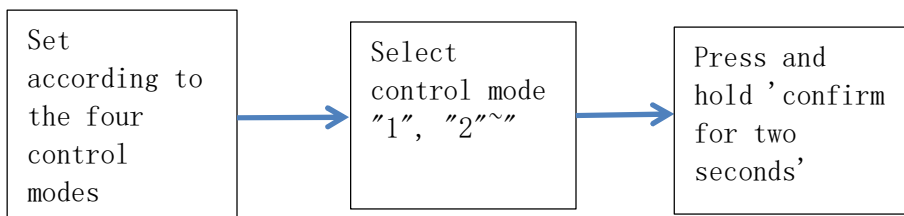

#### Instruction 5: Restore factory value setting:

Description: Restore factory settings.

Operation: Press [5] and [Set Key] quickly. Red light and display the number [1] to select the value for confirmation (press and hold the [set key] for two seconds). [] Blank is to abandon the setting.

